

HYDRAULIC MOTOR-BRAKE MT/B

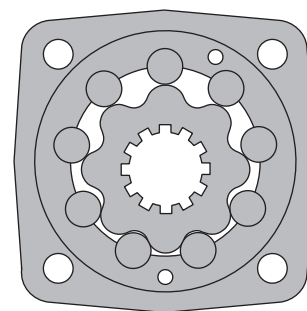

APPLICATION

- » Conveyors
- » Metal working machines
- » Agricultural machines
- » Road building machines
- » Mining machinery
- » Food industries
- » Special vehicles
- » Plastic and rubber machinery etc.



CONTENTS

Specification data	28
Dimensions and mounting	29
Permissible shaft loads	29
Shaft extensions	30
Order code	30

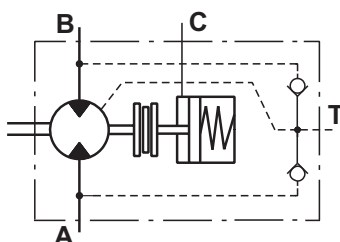

OPTIONS

- » Model - Disc valve, roll-gerotor;
- » Fully integrated friction disk brake;
- » Side ports;
- » Shafts - straight, splined and tapered;
- » BSPP ports
- » Other special features

GENERAL

Max. Displacement, cm ³ /rev [in ³ /rev]	523,6 [31.95]
Max. Speed, [RPM]	780
Max. Torque, daNm [lb-in]	cont.: 122 [10780] int.: 137 [12125]
Max. Output, kW [HP]	40 [54]
Max. Pressure Drop, bar [PSI]	cont.: 200 [2900] int.: 240 [3450]
Max. Oil Flow, lpm [GPM]	150 [40]
Min. Speed, [RPM]	5
Permissible Shaft Loads, daN [lbs]	P _a =1000 [2248]
Pressure fluid	Mineral based- HLP(DIN 51524) or HM(ISO 6743/4)
Temperature range, °C [°F]	-40÷140 [-40÷284]
Optimal Viscosity range, mm ² /s [SUS]	20÷75 [98÷347]
Filtration	ISO code 20/16 (Min. recommended fluid filtration of 25 microns)

Oil flow in drain line

Pressure drop bar [PSI]	Viscosity mm ² /s [SUS]	Oil flow in drain line lpm [GPM]
140 [2030]	20 [98]	2,5 [.66]
	35 [164]	1,5 [.39]
210 [3045]	20 [98]	5 [1.32]
	35 [164]	3 [.79]

Pressure Losses

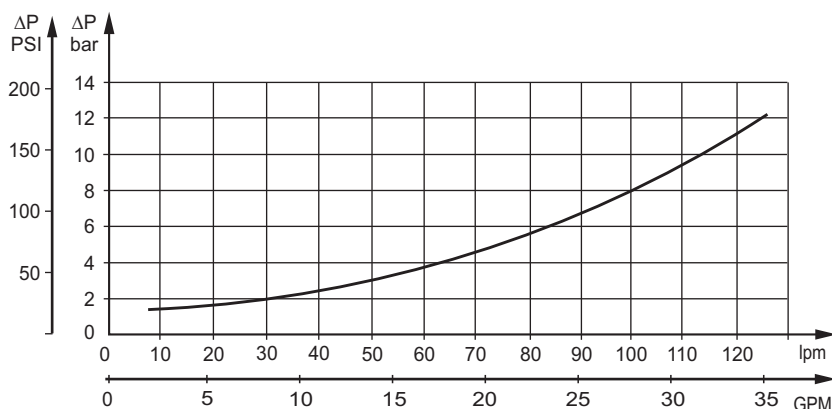

SPECIFICATION DATA

Type		MT/B 160	MT/B 200	MT/B 250	MT/B 315	MT/B 400	MT/B 500
Displacement, cm³/rev [in³/rev]		161,1 [9.83]	201,4 [12.29]	251,8 [15.36]	326,3 [19.90]	410,9 [25.06]	523,6 [31.95]
Max. Speed, [RPM]	Cont.	625	625	500	380	305	240
	Int.*	780	750	600	460	365	285
Max. Torque daNm [lb-in]	Cont.	47 [4160]	59 [5220]	73 [6460]	95 [8410]	108 [9560]	122 [10800]
	Int.*	56 [4960]	71 [6285]	88 [7790]	114 [10090]	126 [11150]	137 [12125]
Max. Output kW [HP]	Cont.	26,5 [36]	33,5 [45]	33,5 [45]	33,5 [45]	30 [40]	26,5 [36]
	Int.*	32 [43]	40 [54]	40 [54]	40 [54]	35 [45]	30 [40]
Max. Pressure Drop bar [PSI]	Cont.	200 [2900]	200 [2900]	200 [2900]	200 [2900]	180 [2600]	160 [2300]
	Int.*	240 [3450]	240 [3450]	240 [3450]	240 [3450]	210 [3050]	180 [2600]
Max. Oil Flow lpm [GPM]	Cont.	100 [26.5]	125 [33]	125 [33]	125 [33]	125 [33]	125 [33]
	Int.*	125 [33]	150 [40]	150 [40]	150 [40]	150 [40]	150 [40]
Max. Inlet Pressure bar [PSI]	Cont.	210 [3050]	210 [3050]	210 [3050]	210 [3050]	210 [3050]	210 [3050]
	Int.*	250 [3600]	250 [3600]	250 [3600]	250 [3600]	250 [3600]	250 [3600]
Max. Return Pressure with Drain Line, bar [PSI]	Cont.	140 [2030]	140 [2030]	140 [2030]	140 [2030]	140 [2030]	140 [2030]
	Int.*	175 [2540]	175 [2540]	175 [2540]	175 [2540]	175 [2540]	175 [2540]
Max. Starting Pressure with Unloaded Shaft, bar [PSI]		10 [150]	10 [150]	10 [150]	10 [150]	10 [150]	10 [150]
Min. Starting Torque daNm [lb-in]	At max. press. drop Cont.	34 [3010]	43 [3800]	53 [4690]	74 [6550]	84 [7435]	95 [8410]
	At max. press. drop Int.*	41 [3630]	52 [4600]	63 [5580]	89 [7880]	97 [8585]	106 [9380]
Min. Speed**, [RPM]		10	9	8	7	6	5
Static Torque of Brake, daNm [lb-in]		143 [12657]	143 [12657]	143 [12657]	143 [12657]	143 [12657]	143 [12657]
Min. Brake Release Pressure***, bar [PSI]		32-35 [2832-3098]	32-35 [2832-3098]	32-35 [2832-3098]	32-35 [2832-3098]	32-35 [2832-3098]	32-35 [2832-3098]
Max. Opening Pressure, bar [PSI]		280 [24782]	280 [24782]	280 [24782]	280 [24782]	280 [24782]	280 [24782]
Max. Pressure in Drain Line, bar [PSI]		5 [443]	5 [443]	5 [443]	5 [443]	5 [443]	5 [443]
Weight, kg [lb]		27,5 [60.6]	28 [61.7]	28,5 [62.8]	29,5 [65]	30,5 [67.2]	31,5 [69.4]

* Intermittent operation: the permissible values may occur for max. 10% of every minute.

** For speeds lower than given, consult factory or your regional manager.

*** Motor-brakes must always have a drain line. The brake release pressure is the difference between the pressure in the brake release line and the pressure in the drain line.

- Intermittent speed and intermittent pressure must not occur simultaneously.
- Recommended filtration is per ISO cleanliness code 20/16. A nominal filtration of 25 micron or better.
- Recommend using a premium quality, anti-wear type mineral based hydraulic oil HLP(DIN51524) or HM (ISO 6743/4). If using synthetic fluids consult the factory for alternative seal materials.
- Recommended minimum oil viscosity 13 mm²/s [70 SUS] at 50°C [122°F].
- Recommended maximum system operating temperature is 82°C [180°F].
- To assure optimum motor life fill with fluid prior to loading and run at moderate load and speed for 10-15 minutes.

DIMENSIONS AND MOUNTING DATA

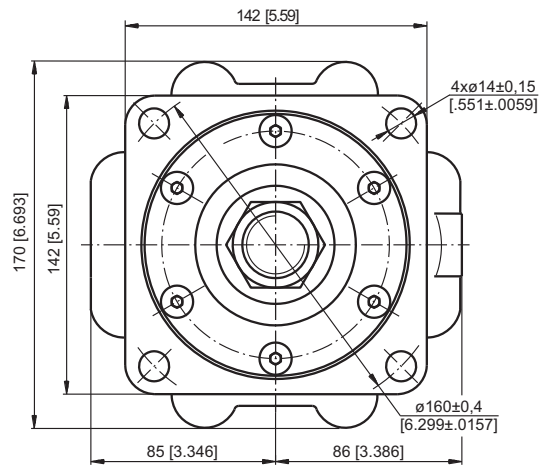
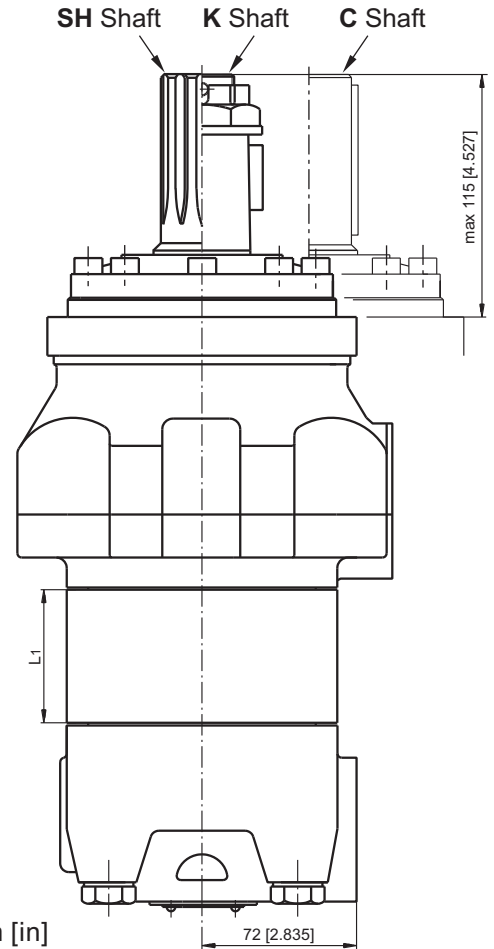
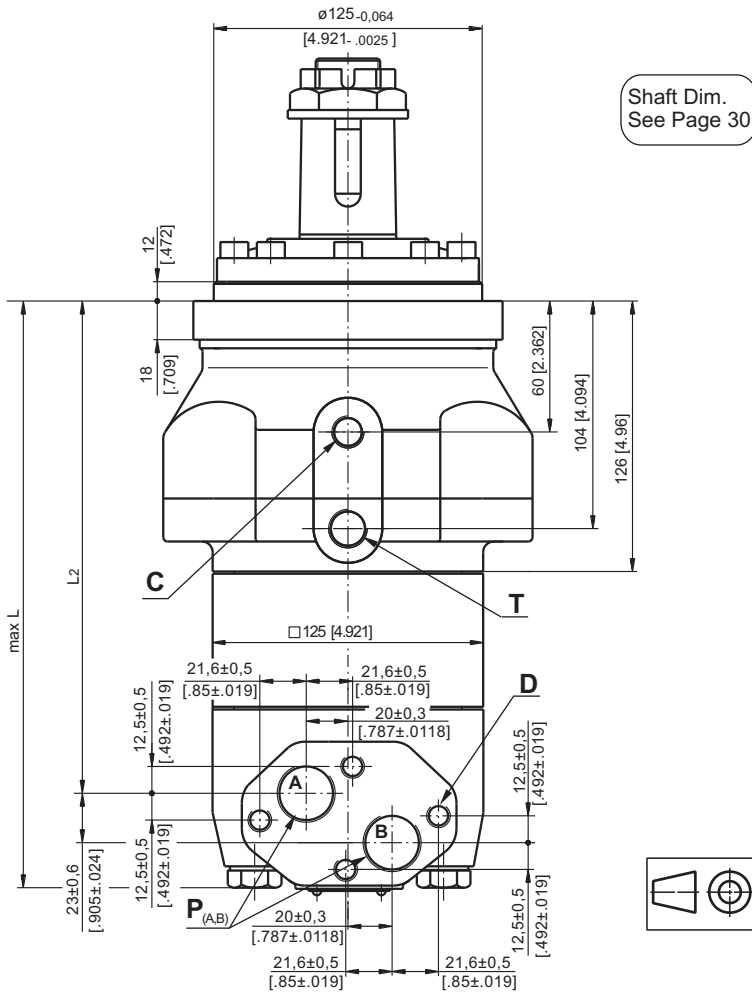

PERMISSIBLE SHAFT LOADS

The curve applies to a B10 bearing life of 3000 hours at 200 RPM.

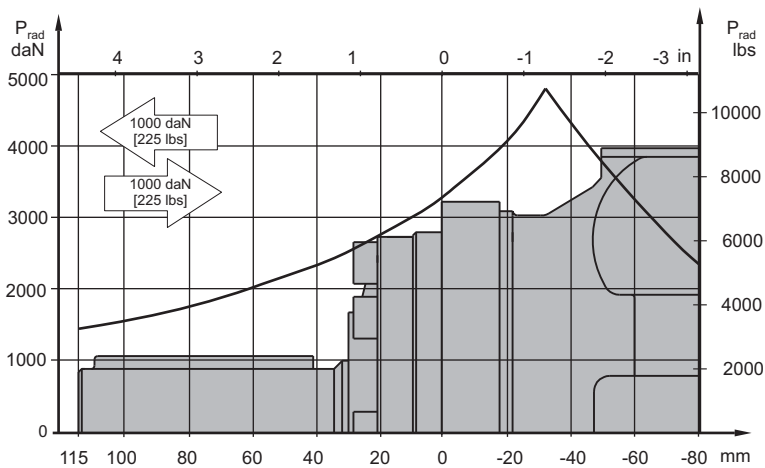

Warning: Drain line should always be used.

- P_(A,B)** - 2xG3/4, 17 mm [.669] depth
- C** - Brake release port, G1/4, 12 mm [.472] depth
- T** - Drainage tap, G3/8, 13 mm [.512] depth
- D** - 4xM10, 10 mm [.394] depth

Type	*L1,mm [in]	L2,mm [in]	L,mm [in]
MT/B 160	16,5 [.65]	178 [7.01]	228 [8.98]
MT/B 200	21,5 [.85]	183 [7.21]	233 [9.17]
MT/B 250	27,8 [1.09]	189,3 [7.45]	239 [9.41]
MT/B 315	37,0 [1.46]	198,5 [7.81]	248 [9.76]
MT/B 400	47,5 [1.87]	209 [8.23]	259 [10.2]
MT/B 500	61,5 [2.42]	223 [8.78]	273 [10.8]

* The width of the gerotor is 3,5 mm [.138] greater than L₁.

SHAFT EXTENSIONS

C - \varnothing 40 straight, Parallel key A12x8x70 DIN 6885
Max. Torque 123 daNm [10886 lb-in]

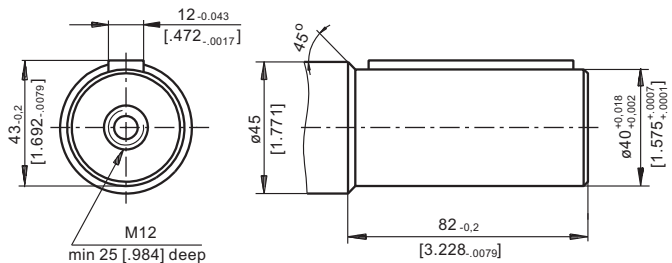

SH - \varnothing 1½" splined 17T, DP 12/24 ANSI B92.1-1976
Max. Torque 123 daNm [10886 lb-in]

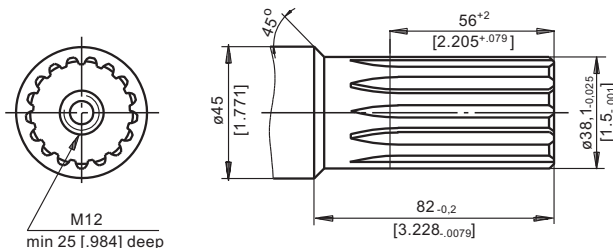

K -tapered 1:10, Parallel key B12x8x28 DIN 6885
Max. Torque 210 daNm [18587 lb-in]

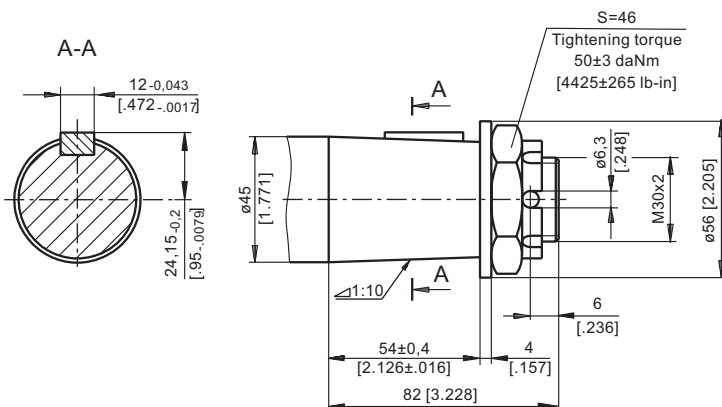

ORDER CODE

	1	2	3	4
MT/B				

Pos.1 - Displacement code

160	- 161,1 cm ³ /rev [9.83 in ³ /rev]
200	- 201,4 cm ³ /rev [12.29 in ³ /rev]
250	- 251,8 cm ³ /rev [15.36 in ³ /rev]
315	- 326,3 cm ³ /rev [19.9 in ³ /rev]
400	- 410,9 cm ³ /rev [25.06 in ³ /rev]
500	- 523,6 cm ³ /rev [31.95 in ³ /rev]

Pos.2 - Shaft Extensions**

C	- \varnothing 40 straight, Parallel key A12x8x70 DIN6885
SH	- \varnothing 1 ½" splined 17 DP12/24 ANS B922.1-76
K	- \varnothing 45 tapered 1:10, Parallel key B12x8x28 DIN 6885

Pos.3 - Special Features (see page 64)

Pos.4 - Design Series

omit - Factory specified

NOTES:

* The permissible output torque for shafts must not be exceeded!

The motor-brakes are mangano-phosphatized as standard.