

HYDRAULIC MOTOR-BRAKE B/MR

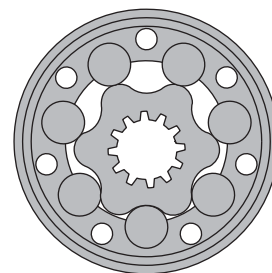

APPLICATION

- » Conveyors
- » Feeding mechanism of robots and manipulators
- » Metal working machines
- » Textile machines
- » Agricultural machines
- » Food industries
- » Mining machinery etc.



CONTENTS

Specification data	22÷23
Dimensions and mounting	24÷25
Shaft extensions	25
Permissible shaft loads	26
Order code	26

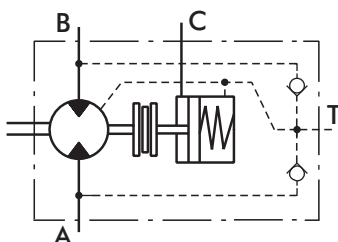

OPTIONS

- » Model - Spool valve, roll-gerotor
- » Fully integrated friction disk brake
- » Side port
- » Shaft - straight
- » BSPP ports

GENERAL

Max. Displacement, cm ³ /rev [in ³ /rev]	397 [24.4]
Max. Speed, [RPM]	600
Max. Torque, daNm [lb-in]	cont.: 61 [5400] int.: 57 [5045]
Max. Output, kW [HP]	14,5 [19.5]
Max. Pressure Drop, bar [PSI]	cont.: 175 [2540] int.: 200 [2900]
Max. Oil Flow, lpm [GPM]	75 [19.8]
Min. Speed, [RPM]	10
Permissible Shaft Loads, daN [lb-in]	P _a =200 [450]
Pressure fluid	Mineral based- HLP(DIN 51524) or HM(ISO 6743/4)
Temperature range, °C [°F]	-40÷140 [-40÷284]
Optimal Viscosity range, mm ² /s [SUS]	20÷75 [98÷347]
Filtration	ISO code 20/16 (Min. recommended fluid filtration of 25 microns)

Oil flow in drain line

Pressure drop bar [PSI]	Viscosity mm ² /s [SUS]	Oil flow in drain line lpm [GPM]
100 [1450]	20 [98]	2,5 [.660]
	35 [164]	1,8 [.476]
140 [2030]	20 [98]	3,5 [.925]
	35 [164]	2,8 [.740]

Pressure Losses

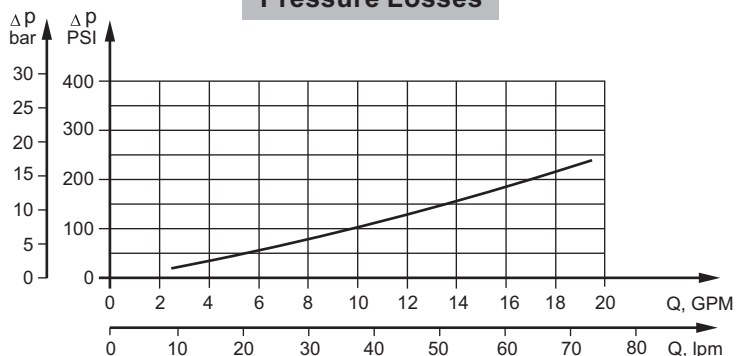

SPECIFICATION DATA

Type		B/MR 80	B/MR 100	B/MR 125	B/MR 160	B/MR 160 CB	B/MR 200	B/MR 200 CB
Displacement, cm ³ /rev [in ³ /rev]		80,3 [4.90]	99,8 [6.09]	125,7 [7.67]	159,6 [9.74]		199,8 [12.19]	
Max. Speed, [RPM]	Cont.	500	500	475	375		300	
	Int.*	600	600	600	470		375	
Max. Torque daNm [lb-in]	Cont.	19,5[1725]	24[2125]	30[2655]	30[2655]	39[3450]	30[2655]	45[3980]
	Int.*	22[1947]	28[2480]	34[3010]	39[3450]	43[3805]	39[3450]	50[4425]
	Peak**	27[2390]	32[2832]	37[3275]	46[4070]	46[4070]	56[4960]	56[4955]
Max. Output kW [HP]	Cont.	8,4 [11.2]	10,8 [14.5]	12,5 [16.8]	10 [13.4]	11,5 [15.4]	7,8 [10.5]	11 [14.75]
	Int.*	9,6 [12.9]	12 [16.1]	14,5 [19.5]	12,5 [16.8]	14 [18.8]	12,4 [16.6]	13 [17.4]
Max. Pressure Drop, bar [PSI]	Cont.	175[2540]	175[2540]	175[2540]	135[1960]	175[2540]	105[1523]	175[2540]
	Int.*	200[2900]	200[2900]	200[2900]	175[2540]	200[2900]	145[2103]	200[2900]
	Peak**	225[3263]	225[3263]	225[3263]	225[3263]	225[3263]	225[3263]	225[3263]
Max. Oil Flow l/min [GPM]	Cont.	40 [10.5]	50 [13.2]	60 [15.9]	60 [15.9]		60 [15.9]	
	Int.*	48 [12.7]	60 [15.9]	75 [19.8]	75 [19.8]		75 [19.8]	
Max. Inlet Pressure bar [PSI]	Cont.	175 [2540]						
	Int.*	200 [2900]						
	Peak**	225 [3260]						
Max. Starting Pressure bar [PSI]		10 [145]	10 [145]	9 [130]	7 [102]		5 [73]	
Min. Starting Torque, daNm [lb-in]	At max.press.drop Cont	15 [1330]	20 [1770]	25 [2215]	24 [2124]	32 [2832]	26 [2301]	41 [3628]
	At max.press.drop Int.*	17 [1505]	23 [2035]	28 [2480]	32 [2832]	37 [3275]	33 [2920]	46 [4071]
Min. Speed***, [RPM]		10	10	10	10	10	10	10
Static Torque of Brake, daNm [lb-in]		55 [4868]						
Min. Brake Release Pressure****, bar [PSI]		13 [190]						
Max. Opening Pressure, bar [PSI]		200 [2900]						
Weight, kg [lb]		11,0 [24.3]	11,2 [24.7]	11,4 [25.2]	11,6 [25.6]	11,7 [25.8]	12,2 [26.9]	12,3 [27.12]

* Intermittent operation: the permissible values may occur for max. 10% of every minute.

** Peak load: the permissible values may occur for max. 1% of every minute.

*** For speeds lower than given, consult factory or your regional manager.

**** Motor-brakes must always have a drain line. The brake release pressure is the difference between the pressure in the brake release line and the pressure in the drain line.

- Intermittent speed and intermittent pressure must not occur simultaneously.
- Recommended filtration is per ISO cleanliness code 20/16. A nominal filtration of 25 micron or better.
- Recommend using a premium quality, anti-wear type mineral based hydraulic oil HLP(DIN51524) or HM (ISO 6743/4).
If using synthetic fluids consult the factory for alternative seal materials.
- Recommended minimum oil viscosity 13 mm²/s [70 SUS] at 50°C [122°F].
- Recommended maximum system operating temperature is 82°C [180°F].
- To assure optimum motor life fill with fluid prior to loading and run at moderate load and speed for 10-15 minutes.

SPECIFICATION DATA (continued)

Type		B/MR 250	B/MR 250 CB	B/MR 315	B/MR 315 CB	B/MR 400	B/MR 400 CB
Displacement, cm ³ /rev [in ³ /rev]		250,1 [15.26]		315,7 [19.26]		397 [24.4]	
Max. Speed, [RPM]	Cont.	240		190		150	
	Int.*	300		240		190	
Max. Torque daNm [lb-in]	Cont.	30 [2655]	54 [4780]	30 [2655]	55 [4868]	30 [2655]	55 [4868]
	Int.*	39 [3450]	57 [5045]	42 [3717]	57 [5045]	43 [3805]	57 [5045]
	Peak**	60 [5310]	71 [6285]	61 [5400]	71 [6285]	60 [5310]	70 [6195]
Max. Output kW [HP]	Cont.	6,2 [8.3]	10 [13.4]	4,5 [6.1]	9 [12.1]	2,2 [2.9]	7 [9.4]
	Int.*	9,5 [12.7]	11 [14.7]	7,5 [10.1]	10 [13.4]	5,6 [7.5]	8,7 [11.7]
Max. Pressure Drop, bar [PSI]	Cont.	85 [1233]	175 [2540]	65 [942]	135 [1958]	45 [652]	105 [1523]
	Int.*	115 [1668]	185 [2683]	90 [1305]	145 [2103]	75 [1087]	115 [1668]
	Peak**	200 [2900]	225 [3263]	150 [2175]	180 [2610]	120 [1740]	140 [2030]
Max. Oil Flow l/min [GPM]	Cont.	60 [15.9]					
	Int.*	75 [19.8]					
Max. Inlet Pressure bar [PSI]	Cont.	175 [2540]					
	Int.*	200 [2900]					
	Peak**	225 [3260]					
Max. Starting Pressure bar [PSI]		5 [73]		5 [73]		5 [73]	
Min. Starting Torque, daNm [lb-in]	At max.press.drop Cont	24 [2125]	50 [4425]	26 [2300]	50 [4425]	24 [2125]	44 [3895]
	At max.press.drop Int.*	31 [2745]	51,5 [4560]	35 [3100]	51,8 [4585]	38 [3364]	50 [4425]
Min. Speed***, [RPM]		10	10	10	10	10	10
Static Torque of Brake, daNm [lb-in]		55 [4868]					
Min. Brake Release Pressure****, bar [PSI]		13 [190]					
Max.Opening Pressure, bar [PSI]		200 [2900]					
Weight, kg [lb]		12,6[27.8]	12,7 [28]	13,3[29.3]	13,4[29.5]	14 [30.9]	14,1[31.1]

* Intermittent operation: the permissible values may occur for max. 10% of every minute.

** Peak load: the permissible values may occur for max. 1% of every minute.

*** For speeds lower than given, consult factory or your regional manager.

**** Motor-brakes must always have a drain line. The brake release pressure is the difference between the pressure in the brake release line and the pressure in the drain line.

- Intermittent speed and intermittent pressure must not occur simultaneously.
- Recommended filtration is per ISO cleanliness code 20/16. A nominal filtration of 25 micron or better.
- Recommend using a premium quality, anti-wear type mineral based hydraulic oil HLP(DIN51524) or HM (ISO 6743/4). If using synthetic fluids consult the factory for alternative seal materials.
- Recommended minimum oil viscosity 13 mm²/s [70 SUS] at 50°C [122°F].
- Recommended maximum system operating temperature is 82°C [180°F].
- To assure optimum motor life fill with fluid prior to loading and run at moderate load and speed for 10-15 minutes.

DIMENSIONS AND MOUNTING DATA

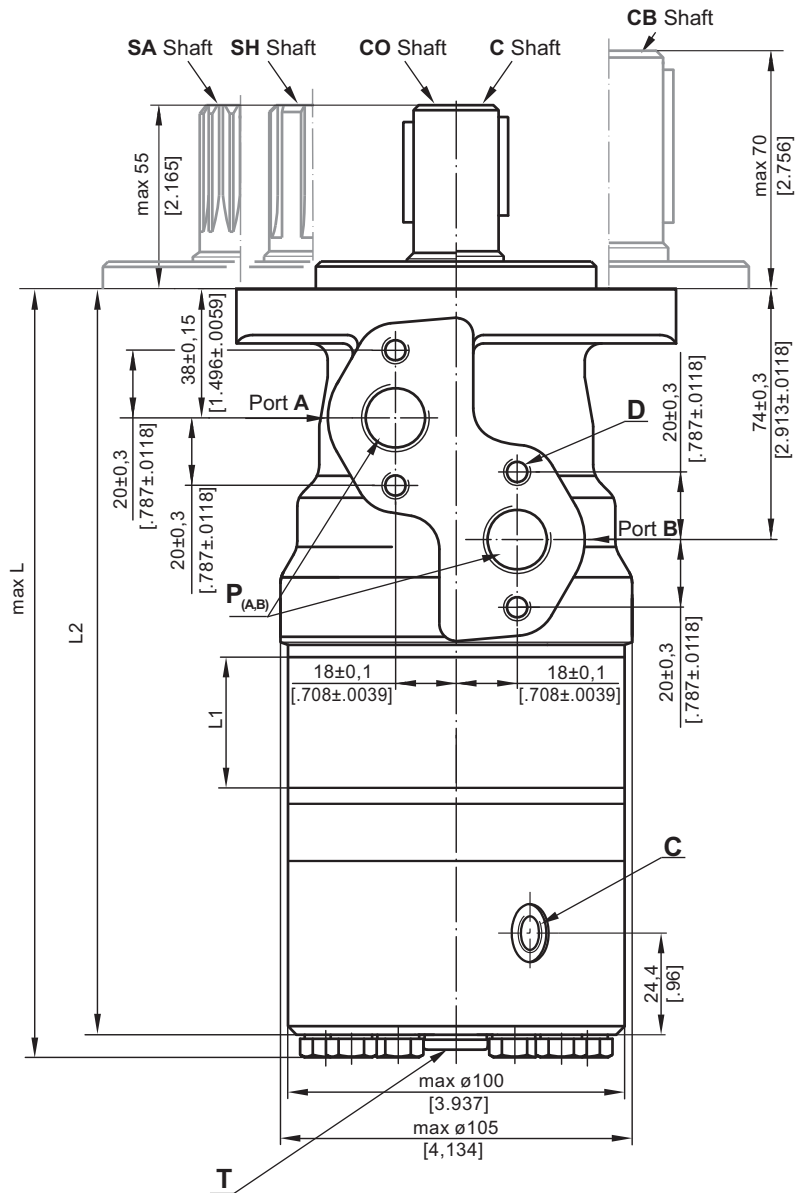

Shaft Dim.
See Page 25

Flange Dim.
See Page 25

- D** : 4xM8 - 13 mm [.51 in] depth
- C** : G1/4 - 12 [.47 in] mm depth
- P_(A,B)** : 2xG1/2 - 15 [.59 in] mm depth
- T** : G1/4 - 10 mm [.393 in] depth

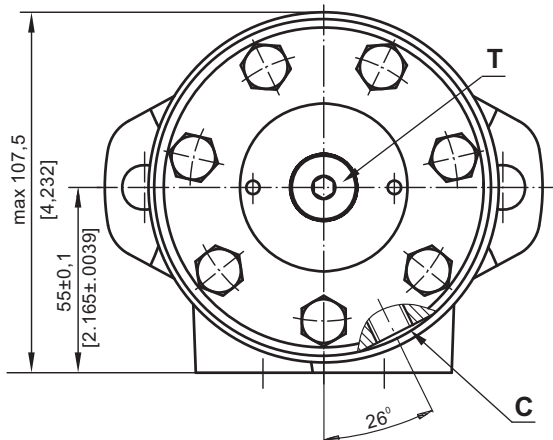

Type	L1, mm [in]	L2, mm [in]	L, mm [in]
B/MR 80	14,0 [.551]	205,5 [8.091]	213,5 [8.405]
B/MR 100	17,4 [.685]	209,0 [8.228]	217,0 [8.543]
B/MR 125	21,8 [.858]	213,5 [8.405]	221,5 [8.720]
B/MR 160	27,8 [1.095]	219,5 [8.642]	227,5 [8.957]
B/MR 200	34,8 [1.37]	226,5 [8.917]	234,5 [9.232]
B/MR 250	43,5 [1.713]	235,0 [9.252]	243,0 [9.567]
B/MR 315	54,8 [2.157]	246,5 [9.705]	254,5 [10.02]
B/MR 400	69,4 [2.732]	261,0 [10.275]	269,0 [10.59]

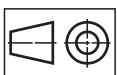

mm [in]

Standard Rotation
Viewed from Shaft End
Port A Pressurized - **CW**
Port B Pressurized - **CCW**

Reverse Rotation
Viewed from Shaft End
Port A Pressurized - **CCW**
Port B Pressurized - **CW**

SHAFT EXTENSIONS

C - $\varnothing 25$ straight, Parallel key A8x7x32 DIN 6885
Max. Torque 34 daNm [3010 lb-in]

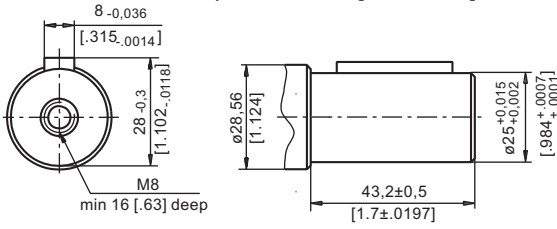

CO - $\varnothing 1''$ straight, Parallel key $\frac{1}{4}'' \times \frac{1}{4}'' \times 1\frac{1}{4}''$ BS46
Max. Torque 34 daNm [3010 lb-in]

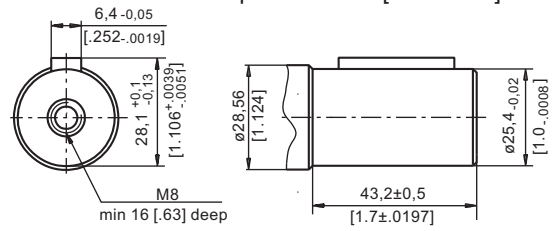

SH - splined, BS 2059 (SAE 6B)
Max. Torque 40 daNm [3540 lb-in]

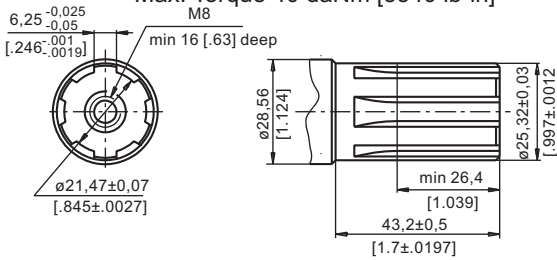

SA - splined, B25x22h9 DIN 5482
Max. Torque 40 daNm [3540 lb-in]

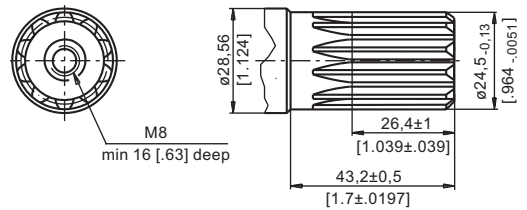

CB - $\varnothing 32$ straight, Parallel key A10x8x45 DIN 6885
Max. Torque 77 daNm [6815 lb-in]

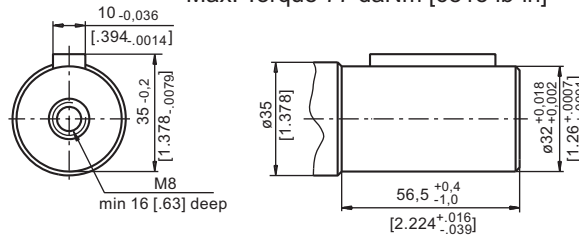

MOUNTING

Oval Mount (2 Holes)

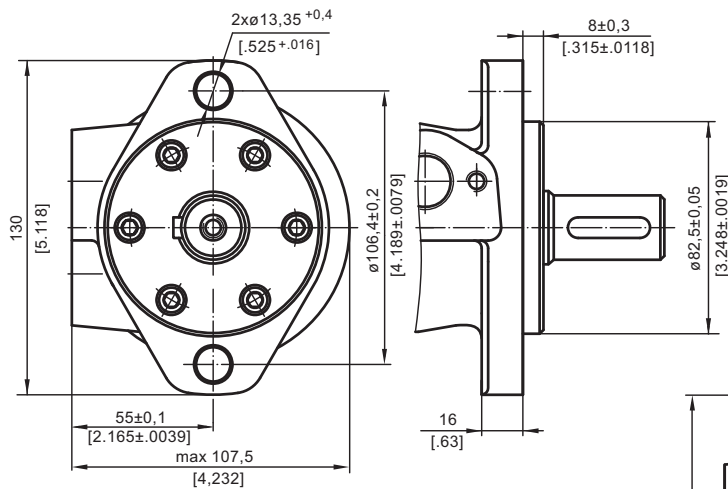

F - Oval Mount (4 Holes)

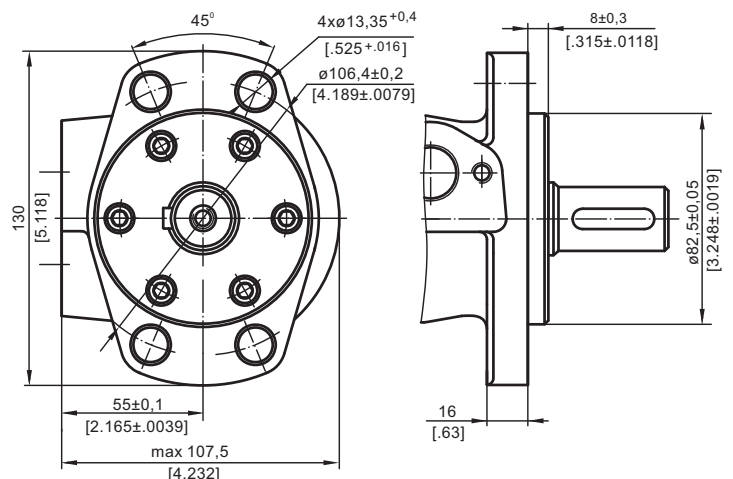

PERMISSIBLE SHAFT LOADS

The permissible radial shaft load P_{rad} depends on the speed n , RPM, distance L from the point of load to the mounting flange and shaft version.

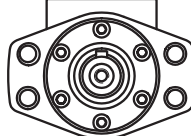
Mounting Flange		
Shaft Version	cylindrical - C, CO splined - SH, SA	cylindrical - CB
Radial Shaft Load P_{rad} , in mm	$\frac{800}{n} \times \frac{25000}{95+L}$, daN*	$\frac{800}{n} \times \frac{18750}{95+L}$, daN*
Radial Shaft Load P_{rad} , in inch	$\frac{800}{RPM} \times \frac{2215}{3.74+L}$, lbs*	$\frac{800}{RPM} \times \frac{1660}{3.74+L}$, lbs*

* $n \leq 200$ RPM; max $P_{rad}=800$ daN [1800 lbs] $n \geq 200$ RPM; $L < 55$ mm [2.2 in]

Radial Shaft Load P_{rad} for C, CO Shaft Extensions by $L=30$ mm [1.18 in]

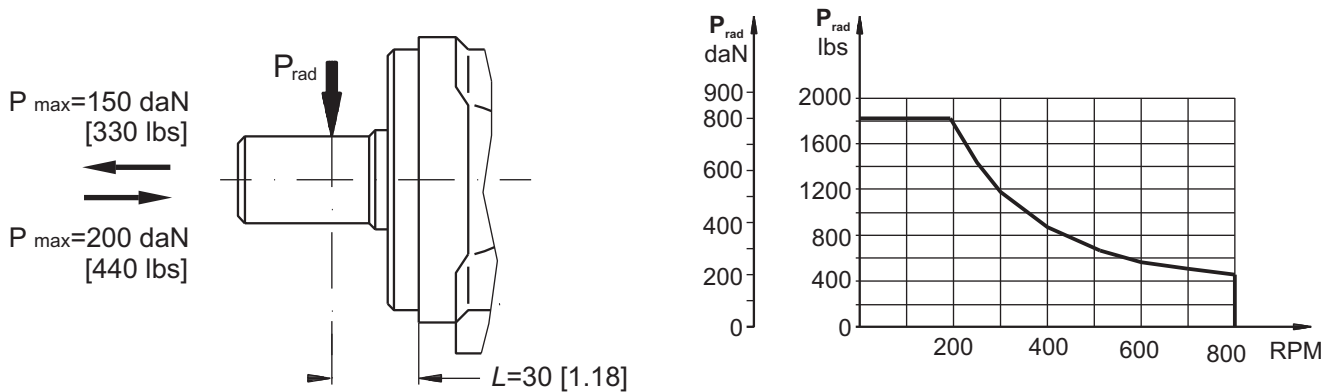

ORDER CODE

1	2	3	4	5
B / M R				

Pos.1 - Mounting Flange

- omit - Oval mount, two holes
- F** - Oval mount, four holes

Pos.2 - Displacement code

80	- 80,3 cm ³ /rev [4.90 in ³ /rev]
100	- 99,8 cm ³ /rev [6.09 in ³ /rev]
125	- 125,7 cm ³ /rev [7.67 in ³ /rev]
160	- 159,6 cm ³ /rev [9.74 in ³ /rev]
200	- 199,8 cm ³ /rev [12.19 in ³ /rev]
250	- 250,1 cm ³ /rev [15.26 in ³ /rev]
315	- 315,7 cm ³ /rev [19.26 in ³ /rev]
400	- 397,0 cm ³ /rev [24.40 in ³ /rev]

Pos.3 - Shaft Extensions*

C	- $\varnothing 25$ straight, Parallel key A8x7x32 DIN6885
CO	- $\varnothing 1$ " straight, Parallel key $\frac{1}{4}$ "x $\frac{1}{4}$ "x $1\frac{1}{4}$ " BS46
SH	- $\varnothing 25,32$ splined BS 2059 (SAE 6B)
SA	- $\varnothing 24,5$ splined B 25x22 DIN 5482
CB	- $\varnothing 32$ straight, Parallel key A10x8x45 DIN 6885

Pos.4 - Special Features (see page 64)

Pos.5 - Design Series

- omit - Factory specified

NOTES:

* The permissible output torque for shafts must not be exceeded!

The motor-brakes are mangano-phosphatized as standard.