

HYDRAULIC MOTORS MTM

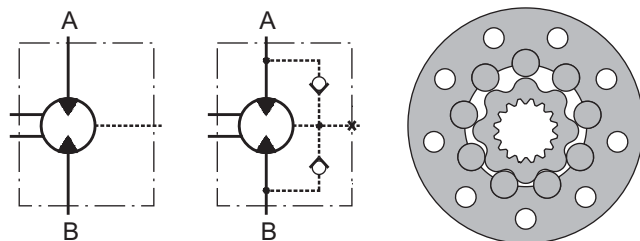

APPLICATION

- » Skid Steer Loaders
- » Metal working machines
- » Trenchers
- » Augers
- » Agricultural machines
- » Road building machines
- » Special vehicles
- » Mine machines
- » Woodworking and sawmill machinery
- » Conveyors etc.



CONTENTS

Specification data	18
Function diagrams	19÷21
Dimensions and mounting	22÷24
Shaft extensions	25
Permissible shaft loads	25
Dimensions and mounting- MTMV	26
Dimensions and mounting- MTM6V	27
Internal Spline data	28
Order code	28

OPTIONS

- » Model - Disc valve, roll-gerotor
- » Flange with wheel mount
- » Short motor
- » Side ports
- » Shafts - straight, splined and tapered
- » BSPP ports;
- » Other special features.

EXCELLENCE

- » High torque and pressure drop
- » High inlet pressure
- » High starting torque
- » Improved efficiency at high pressure drop
- » Smooth operation at low speed

GENERAL

Max. Displacement, cm ³ /rev [in ³ /rev]	724,3 [44.2]
Max. Speed, [RPM]	750
Max. Torque, daNm [lb-in]	cont.: 183 [16200] int.: 229 [20270]
Max. Output, kW [HP]	70 [94]
Max. Pressure Drop, bar [PSI]	cont.: 250 [3600] int.: 350 [5080]
Max. Oil Flow, lpm [GPM]	150 [40]
Min. Speed, [RPM]	5
Permissible Shaft Loads daN [lbs]	P _a =1000 [2250]
Pressure fluid	Mineral based- HLP(DIN 51524) or HM(ISO 6743/4)
Temperature range, °C [°F]	-40÷140 [-40÷284]
Optimal Viscosity range, mm ² /s [SUS]	20÷75 [98÷347]
Filtration	ISO code 20/16 (Min. recommended fluid filtration of 25 microns)

Oil flow in drain line

Pressure drop bar [PSI]	Viscosity mm ² /s [SUS]	Oil flow in drain line lpm [GPM]
140 [2030]	20 [98]	2,5 [.660]
	35 [164]	1,5 [.396]
210 [3045]	20 [98]	5 [1.321]
	35 [164]	3 [.793]

Pressure Losses

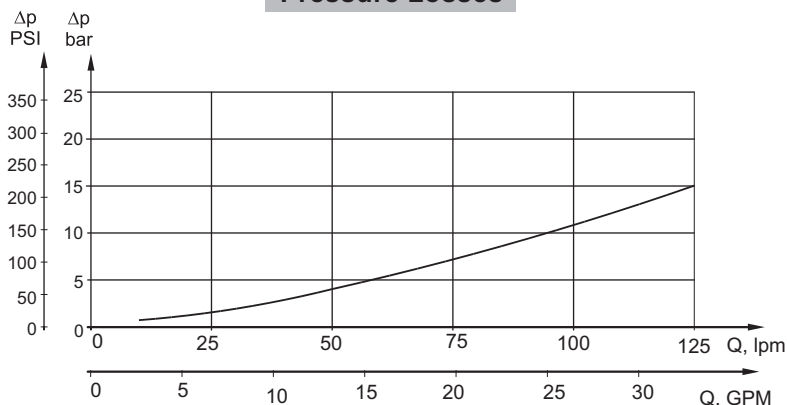

SPECIFICATION DATA

Type		MTM 200	MTM 250	MTM 315	MTM 400	MTM 470	MTM 500	MTM 630	MTM 725
Displacement, cm³/rev [in³/rev]		201,4 [12.29]	251,8 [15.36]	326,3 [19.9]	410,9 [25.06]	475 [28.97]	523,6 [31.95]	631,2 [38.52]	724 [44.2]
Max. Speed, [RPM]	Cont.	625	500	380	305	260	240	190	170
	Int.*	750	600	460	365	315	285	230	215
Max. Torque daNm [lb-in]	Cont.	74 [6550]	90[7965]	116[10265]	147[13010]	171[15135]	172[15225]	183[16200]	160[14160]
	Int.*	102[9030]	128[11330]	163[14425]	206[18232]	215[16030]	215[16030]	229[20270]	192[17000]
	Peak**	115[10180]	144[12745]	186[16460]	235[20800]	240[21240]	240[21240]	274[24250]	240[21240]
Max. Output kW [HP]	Cont.	41 [55]	41 [55]	41 [55]	41 [55]	41 [55]	37,5[50]	28 [37,5]	26 [35]
	Int.*	70 [94]	70 [94]	70 [94]	70 [94]	55 [74]	51 [68]	42 [56]	40 [54]
Max. Pressure Drop bar [PSI]	Cont.	250[3600]	250[3600]	250[3600]	250[3600]	250[3600]	230[3340]	200[2900]	160[2320]
	Int.*	350[5080]	350[5080]	350[5080]	350[5080]	315[4570]	280[4060]	250[3625]	210[3045]
	Peak**	400[5800]	400[5800]	400[5800]	400[5800]	350[5080]	320[4640]	300[4350]	260[3770]
Max. Oil Flow lpm [GPM]	Cont.	125[33]	125[33]	125[33]	125[33]	125[33]	125[33]	125[33]	125[33]
	Int.*	150[40]	150[40]	150[40]	150[40]	150[40]	150[40]	150[40]	150[40]
Max. Inlet Pressure bar [PSI]	Cont.	270[3920]	270[3920]	270[3920]	270[3920]	270[3920]	270[3920]	270[3920]	270[3920]
	Int.*	370[5370]	370[5370]	370[5370]	370[5370]	370[5370]	370[5370]	370[5370]	370[5370]
	Peak**	420[6100]	420[6100]	420[6100]	420[6100]	420[6100]	420[6100]	420[6100]	420[6100]
Max. Return Pressure without Drain Line or Max. Pressure in Drain Line, bar [PSI]	Cont. 0-100 RPM	75 [1100]	75 [1100]	75 [1100]	75 [1100]	75 [1100]	75 [1100]	75 [1100]	75 [1100]
	Cont. 100-300 RPM	40 [580]	40 [580]	40 [580]	40 [580]	40 [580]	40 [580]	40 [580]	40 [580]
	Cont. >300 RPM	20 [290]	20 [290]	20 [290]	20 [290]	20 [290]	-	-	-
	Int.* 0-max. RPM	75 [1100]	75 [1100]	75 [1100]	75 [1100]	75 [1100]	75 [1100]	75 [1100]	75 [1100]
Max. Return Pressure with Drain Line bar [PSI]	Cont.	140 [2000]	140 [2000]	140 [2000]	140 [2000]	140 [2000]	140 [2000]	140 [2000]	140 [2000]
	Int.*	175 [2500]	175 [2500]	175 [2500]	175 [2500]	175 [2500]	175 [2500]	175 [2500]	175 [2500]
	Peak**	210 [3000]	210 [3000]	210 [3000]	210 [3000]	210 [3000]	210 [3000]	210 [3000]	210 [3000]
Max. Starting Pressure with Unloaded Shaft, bar [PSI]		6 [90]	6 [90]	6 [90]	6 [90]	6 [90]	6 [90]	6 [90]	6 [90]
Min. Starting Torque daNm [lb-in]		60[5310]	75[6640]	97[8585]	122[10800]	142[12570]	143[12655]	145[12830]	148[13100]
Min. Speed***, [RPM]		5	5	5	5	5	5	5	5
Weight, kg [lb]	MTM	26,9 [59.3]	27,3 [60.2]	28,1 [62]	29 [64]	29,7 [65.5]	30,2 [66.6]	29,7 [65.5]	31 [68.4]
	MTMW	27,4 [60.4]	27,8 [61.3]	28,6 [63.1]	29,5 [65.1]	30,2 [66.6]	30,7 [67.7]	30,2 [66.6]	31,5 [69.5]
	MTMV	15,7 [34.6]	16,1 [35.5]	16,9 [37.3]	17,8 [39.3]	18,5 [40.8]	19 [41.9]	18,5 [40.8]	19,8 [43.7]

* Intermittent operation: the permissible values may occur for max. 10% of every minute.

** Peak load: the permissible values may occur for max. 1% of every minute.

*** For speeds lower than given, consult factory or your regional manager.

- Intermittent speed and intermittent pressure must not occur simultaneously.
- Recommended filtration is per ISO cleanliness code 20/16. A nominal filtration of 25 micron or better.
- Recommend using a premium quality, anti-wear type mineral based hydraulic oil, HLP(DIN51524) or HM(ISO6743/4).
If using synthetic fluids consult the factory for alternative seal materials.
- Recommended minimum oil viscosity 13 mm²/s [70 SUS] at 50°C [122°F].
- Recommended maximum system operating temperature is 82°C [180°F].
- To assure optimum motor life fill with fluid prior to loading and run at moderate load and speed for 10-15 minutes.

FUNCTION DIAGRAMS

MTM 250

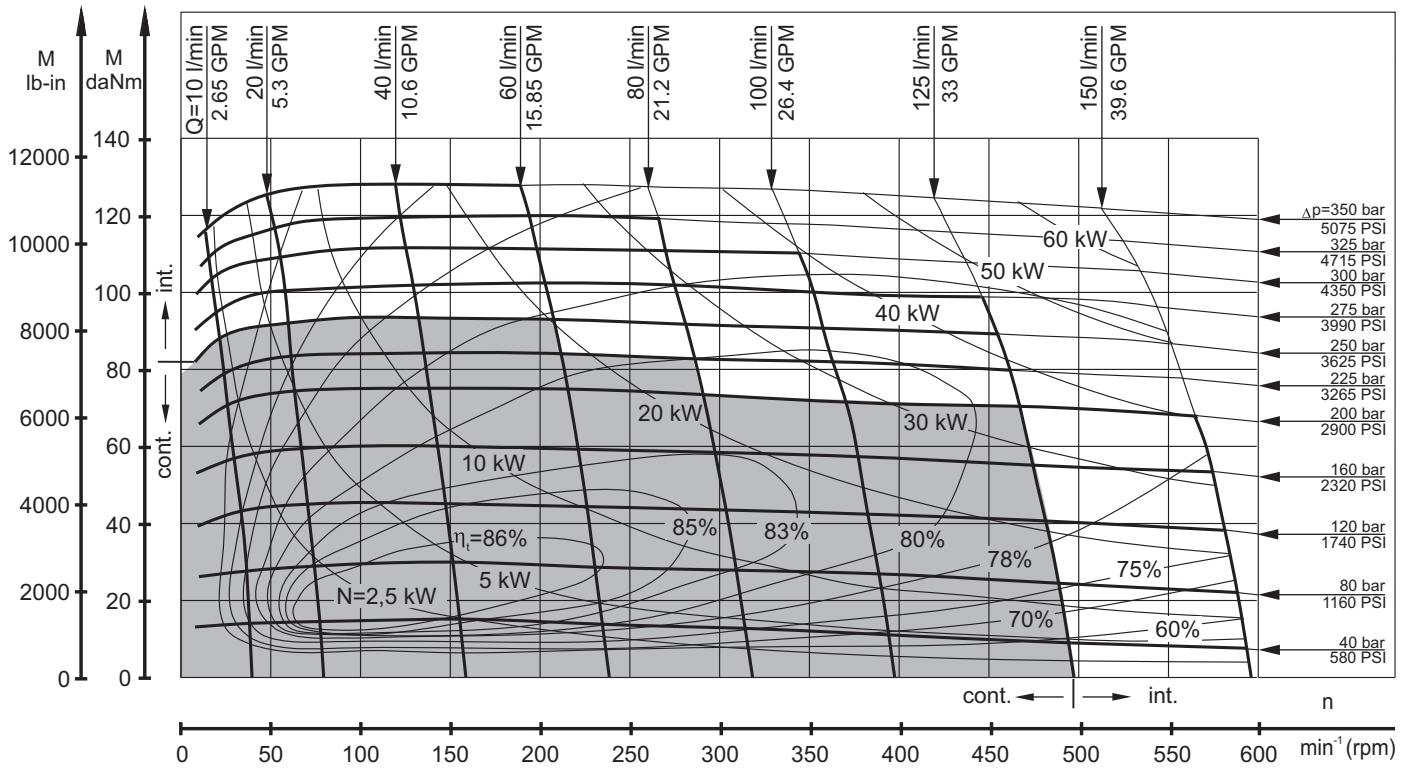

MTM 315

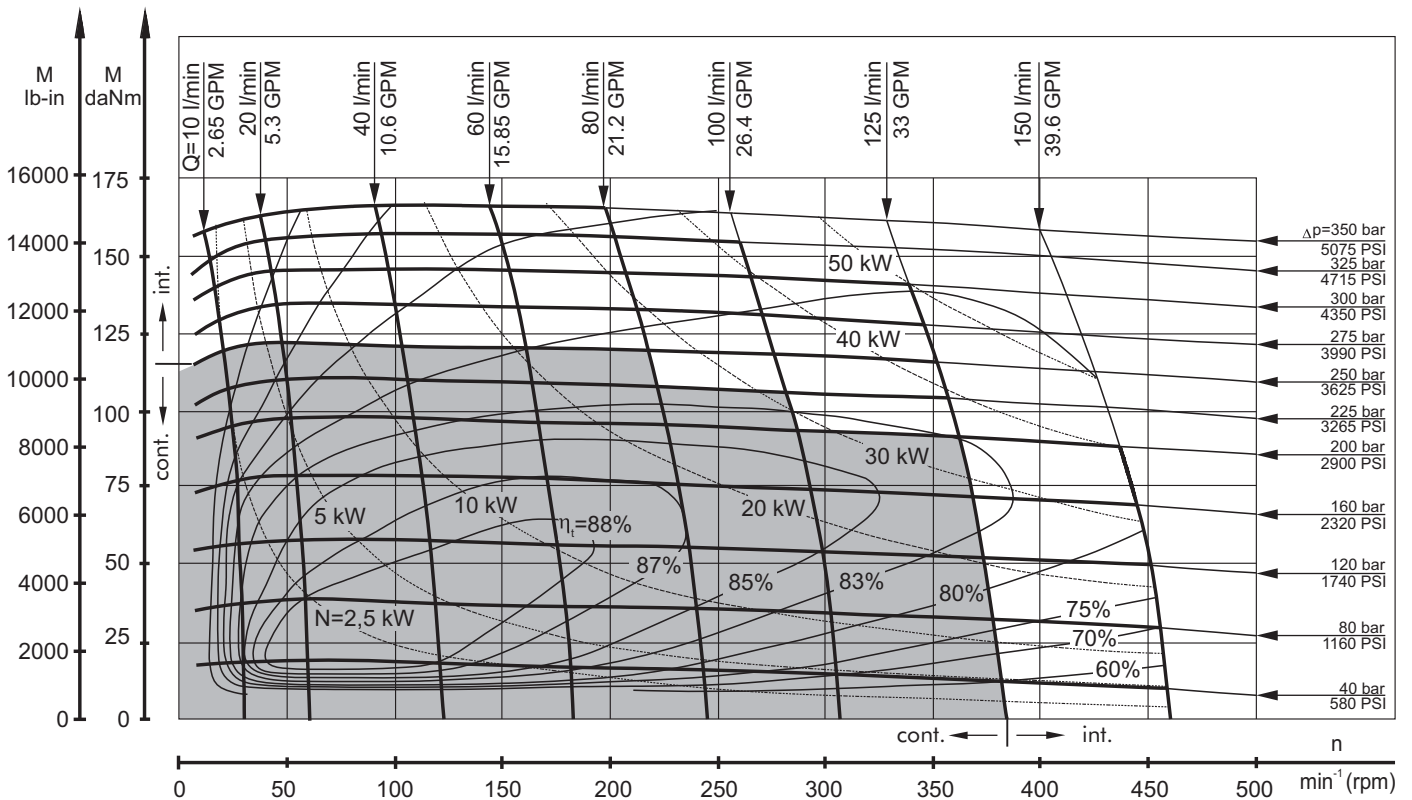

The function diagrams data was collected at back pressure 5÷10 bar (72.5PSI÷145PSI) and oil with viscosity of 32 mm²/s [150SUS] at 50° C [122°F].

FUNCTION DIAGRAMS

MTM 400

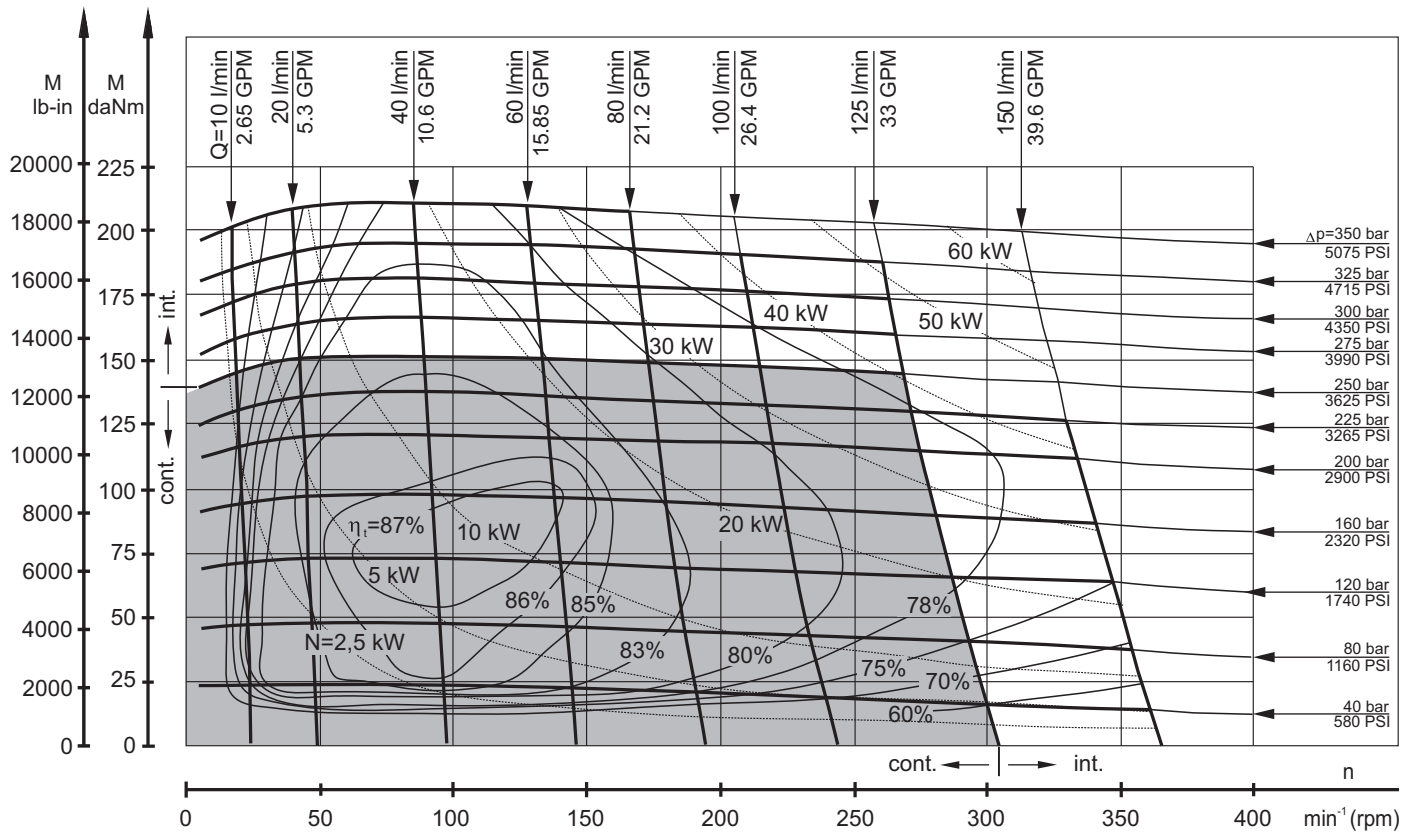

MTM 470

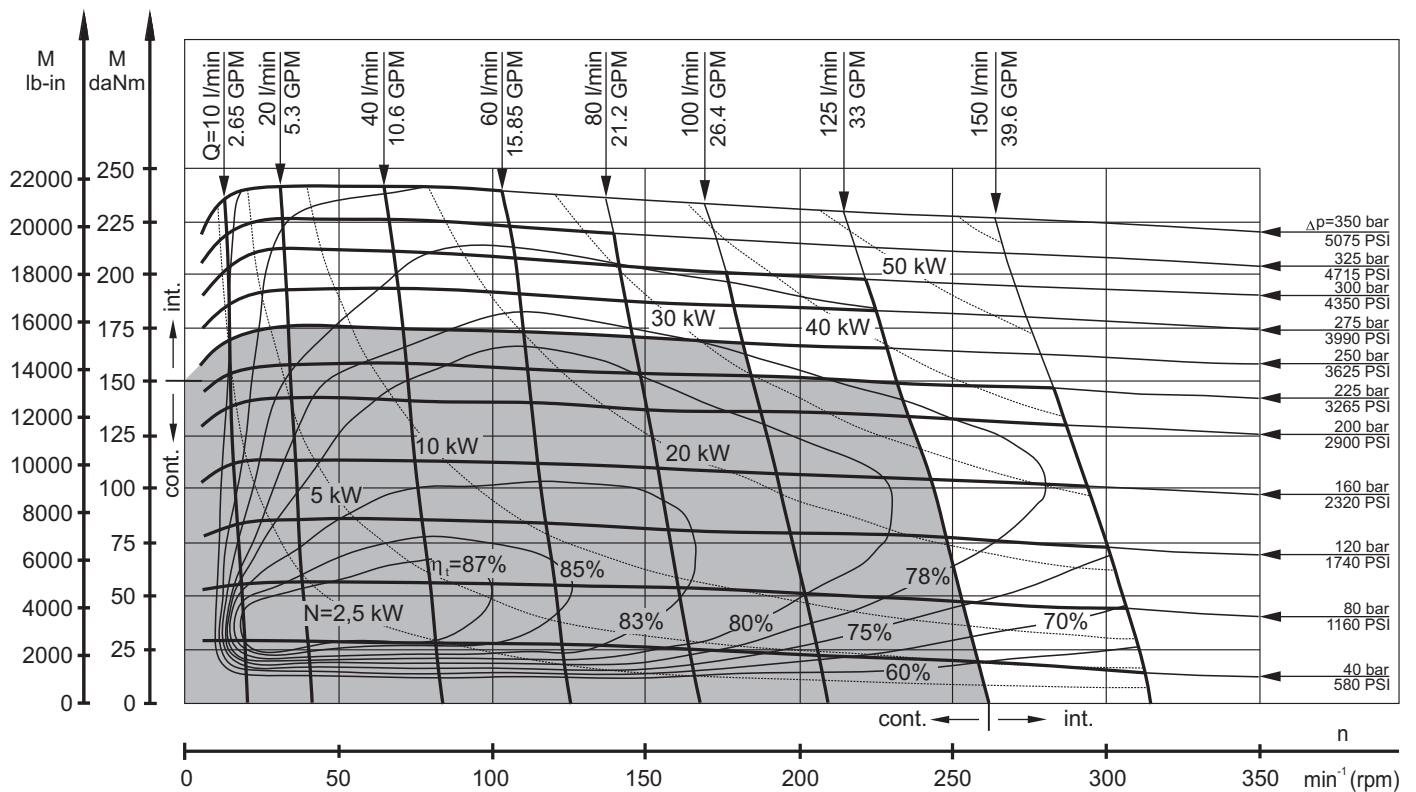

The function diagrams data was collected at back pressure 5÷10 bar (72.5PSI÷145PSI) and oil with viscosity of 32 mm²/s [150SUS] at 50° C [122°F].

FUNCTION DIAGRAMS

MTM 500

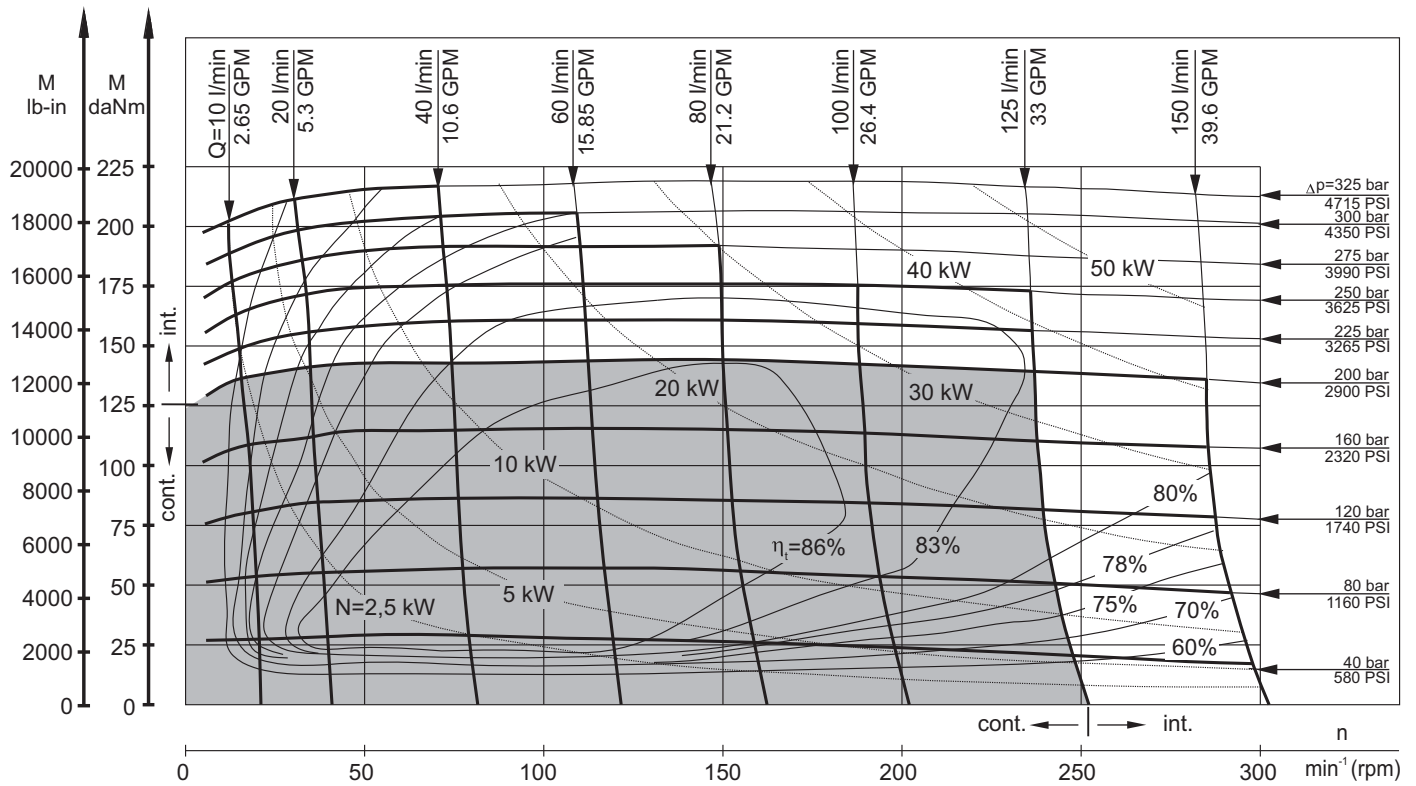

MTM 630

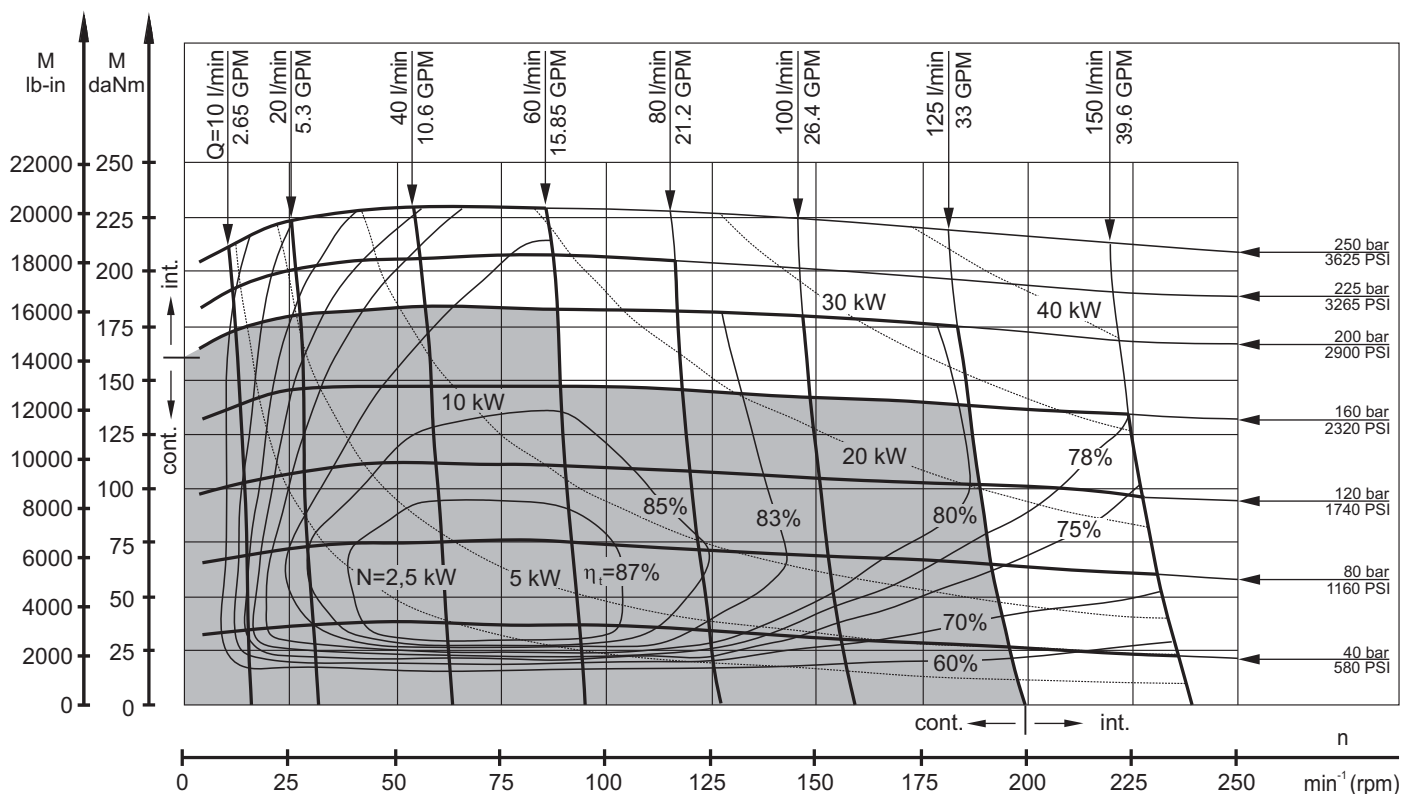

The function diagrams data was collected at back pressure 5÷10 bar (72.5PSI÷145PSI) and oil with viscosity of 32 mm²/s [150SUS] at 50° C [122°F].

DIMENSIONS AND MOUNTING DATA - MTM and MTMC

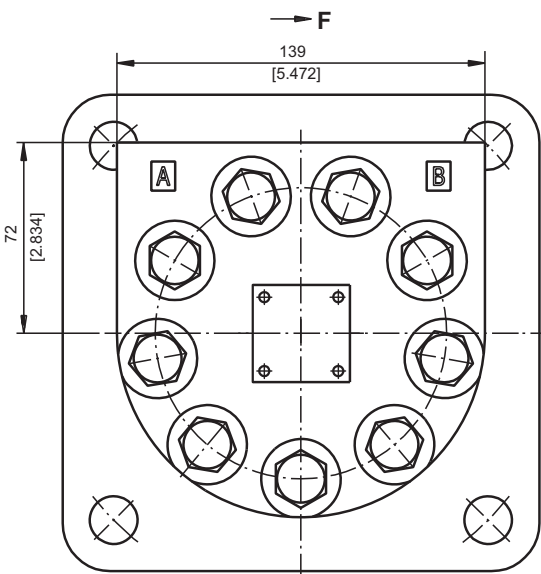
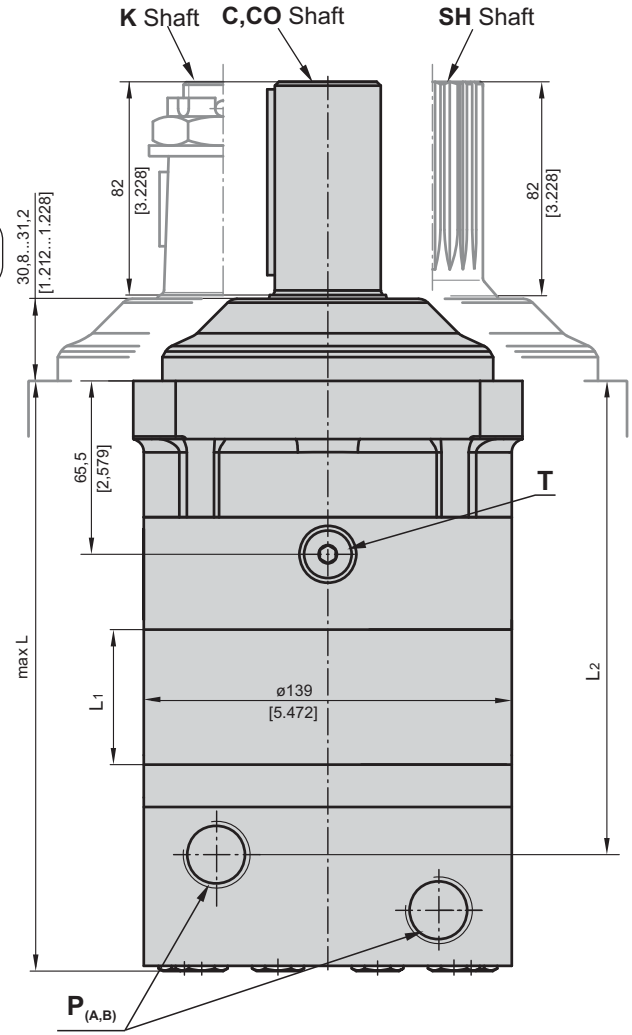
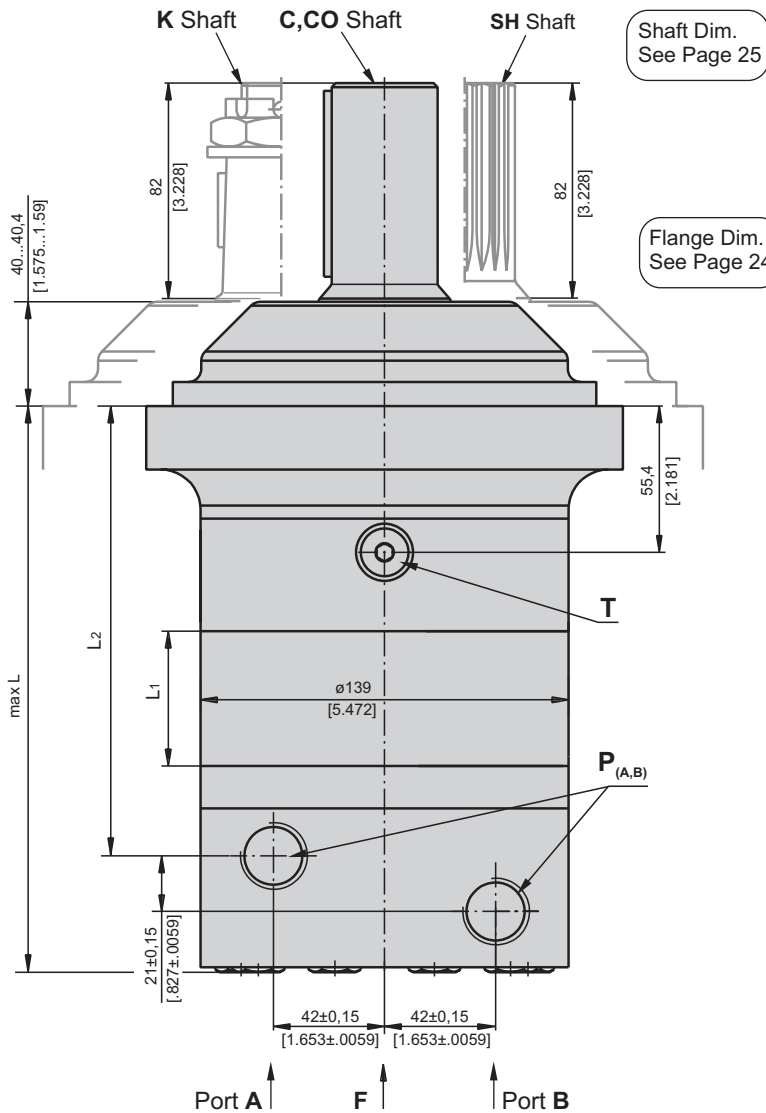

T - Drain port

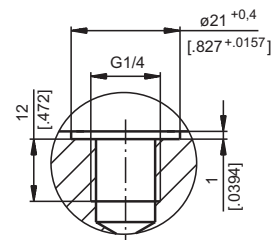

Warning: Drain line should always be used.

P_(A,B): 2xG3/4 - 17 mm [0.669 in] depth

T : G1/4 - 12 mm [0.472 in] depth (plugged)

Type	L, mm [in]	L ₂ , mm [in]	Type	L, mm [in]	L ₂ , mm [in]	L ₁ , mm [in]
MTM 200	188 [7.40]	142,3 [5.60]	MTMC 200	198 [7.79]	153 [6.02]	25 [0.98]
MTM 250	194 [7.64]	148,6 [5.85]	MTMC 250	204,5 [8.05]	159,3 [6.27]	31,3 [1.23]
MTM 315	203 [7.99]	157,8 [6.21]	MTMC 315	213,5 [8.40]	168,5 [6.63]	40,5 [1.59]
MTM 400	214 [8.43]	168,3 [6.63]	MTMC 400	224 [8.82]	179 [7.04]	51 [2.01]
MTM 470	222 [8.74]	176,3 [6.94]	MTMC 470	232 [9.13]	187 [7.36]	59 [2.32]
MTM 500	228 [8.98]	182,3 [7.18]	MTMC 500	238 [9.37]	193 [7.60]	65 [2.56]
MTM 630	224 [8.82]	178,3 [7.02]	MTMC 630	234 [9.21]	189 [7.44]	61 [2.40]
MTM 725	233 [9.17]	187,3 [7.37]	MTMC 725	243 [9.56]	198 [7.79]	70 [2.76]

Standard Rotation
Viewed from Shaft End
Port A Pressurized - **CW**
Port B Pressurized - **CCW**

Reverse Rotation
Viewed from Shaft End
Port A Pressurized - **CCW**
Port B Pressurized - **CW**



DIMENSIONS AND MOUNTING DATA - MTMW

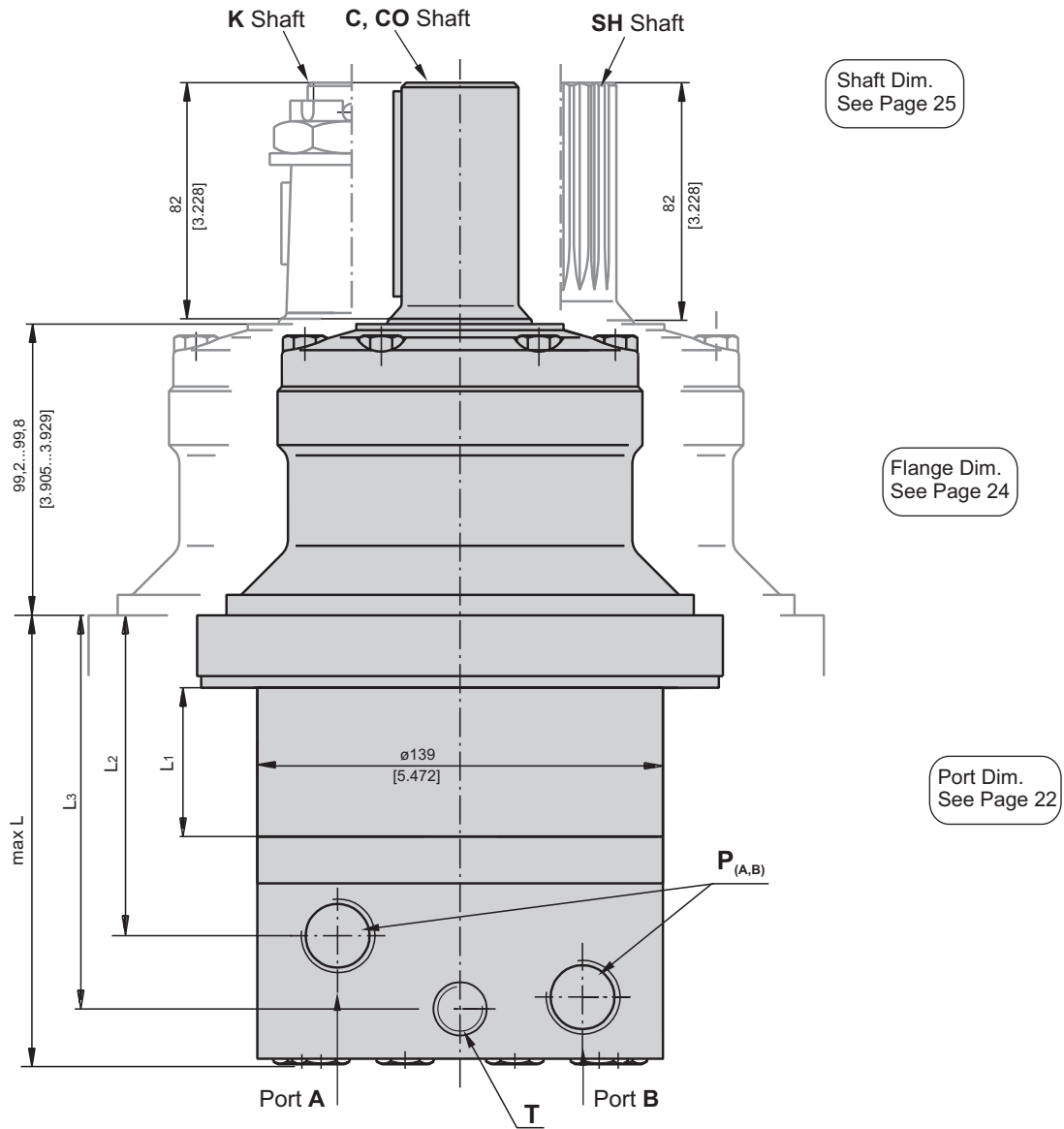

Warning: Drain line should always be used.

P_(A, B): 2xG3/4 - 17 mm [.669 in] depth
T : G1/4 - 12 mm [.472 in] depth (plugged)

Type	L, mm [in]	L ₁ , mm [in]	L ₂ , mm [in]	L ₃ , mm [in]
MTMW 200	129 [5.08]	25 [.98]	83,8 [3.30]	111,1 [3.37]
MTMW 250	135 [5.32]	31,3 [1.23]	90,1 [3.55]	117,4 [4.62]
MTMW 315	144 [5.67]	40,5 [1.59]	99,3 [3.91]	126,6 [4.98]
MTMW 400	155 [6.10]	51 [2.01]	109,8 [4.32]	137,1 [5.40]
MTMW 470	163 [6.42]	59 [2.32]	117,8 [4.64]	145,1 [5.71]
MTMW 500	169 [6.65]	65 [2.56]	123,8 [4.87]	151,1 [5.95]
MTMW 630	165 [6.50]	61 [2.40]	119,8 [4.72]	147,1 [5.79]
MTMW 725	174 [6.85]	70 [2.76]	128,8 [5.07]	156,1 [6.15]

Standard Rotation
 Viewed from Shaft End
 Port A Pressurized - **CW**
 Port B Pressurized - **CCW**

Reverse Rotation
 Viewed from Shaft End
 Port A Pressurized - **CCW**
 Port B Pressurized - **CW**



MOUNTING

4-Bolt flange
spigot diameter $\varnothing 160$ mm [6.3 in] - BC $\varnothing 200$ [7.874 in] mm

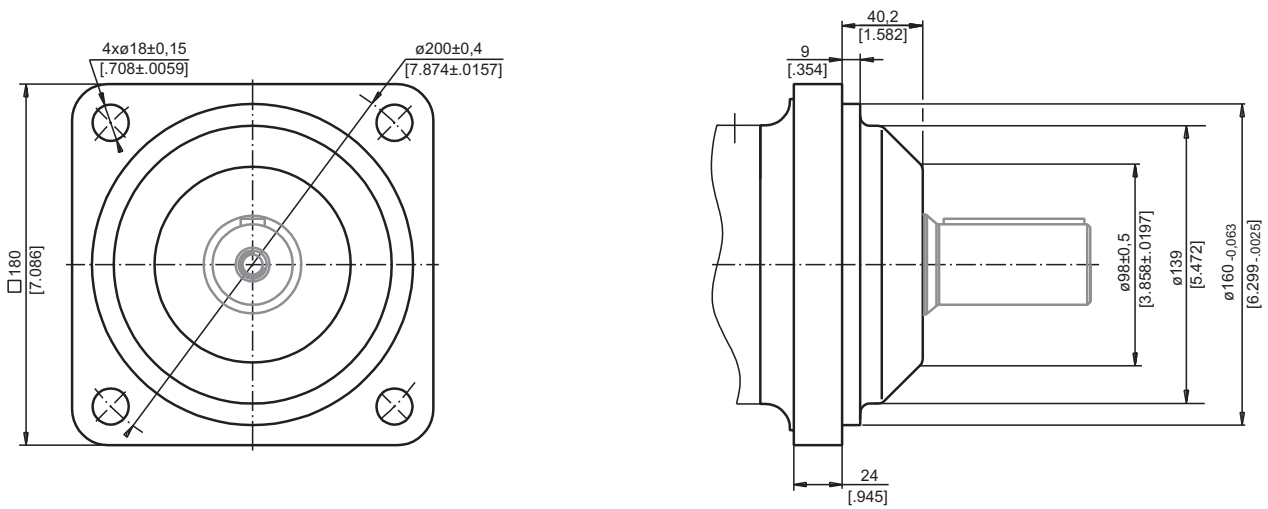

C 4-Bolt flange
spigot diameter $\varnothing 125$ mm [4.921 in] - BC $\varnothing 160$ mm [6.3 in]

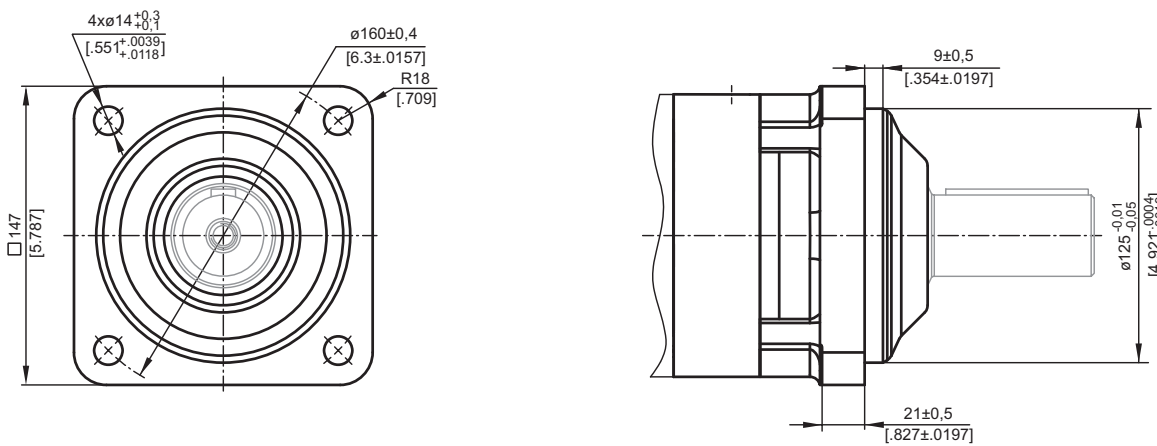

W 4-Bolt flange, Wheel Motor
spigot diameter $\varnothing 160$ mm [6.3 in] - BC $\varnothing 200$ mm [7.874 in]

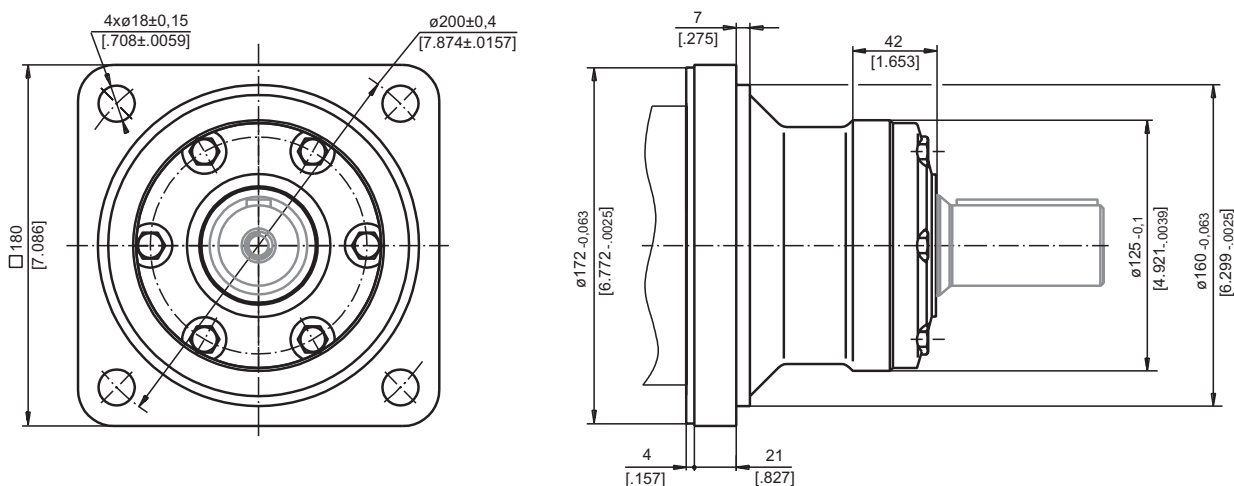

SHAFT EXTENSIONS

C - $\varnothing 40$ straight, Parallel key A12x8x70 DIN 6885
Max. Torque 132,8 daNm [11755 lb-in]

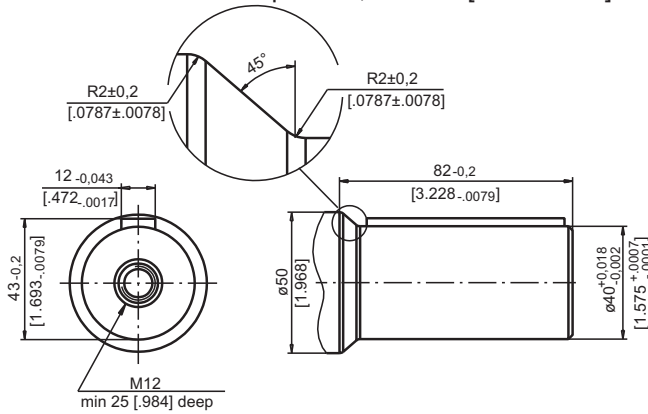

SH - $\varnothing 1\frac{1}{2}$ " splined 17T, DP 12/24 ANSI B92.1-1976
Max. Torque 132,8 daNm [11755 lb-in]

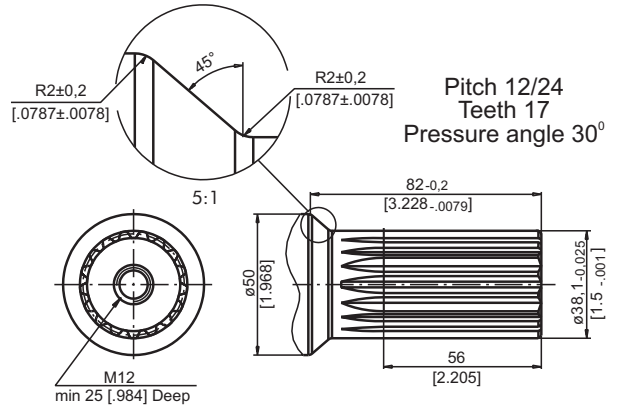

CO - $\varnothing 1\frac{1}{2}$ " straight, Parallel key $\frac{3}{8}$ " x $\frac{3}{8}$ " x $\frac{1}{4}$ " BS46
Max. Torque 132,8 daNm [11755 lb-in]

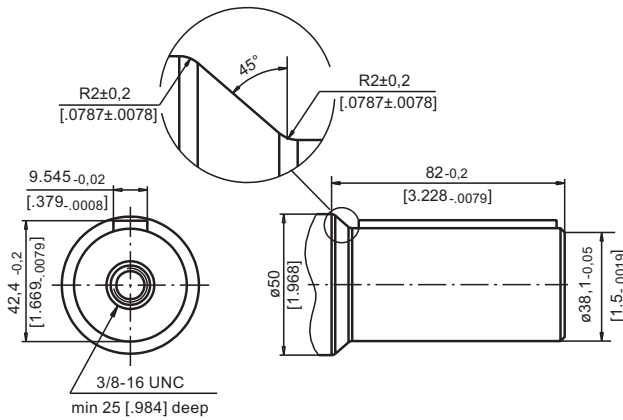

K - tapered 1:10, Parallel key B12x8x28 DIN 6885
Max. Torque 210,7 daNm [18650 lb-in]

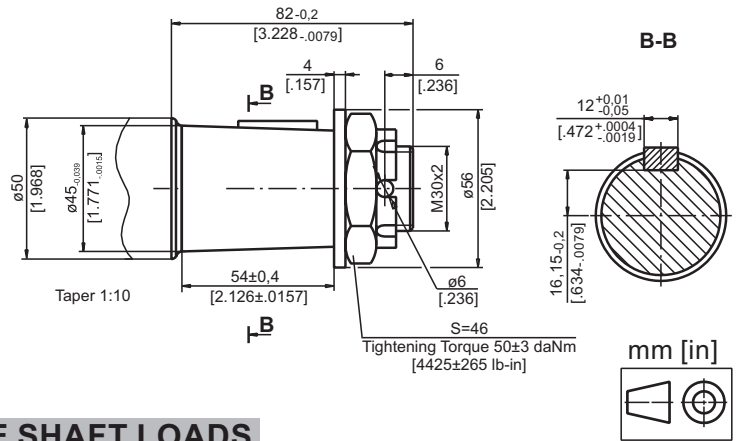

PERMISSIBLE SHAFT LOADS

The curves apply to a B10 bearing life (ISO281) of 2000 hours at 200 RPM.

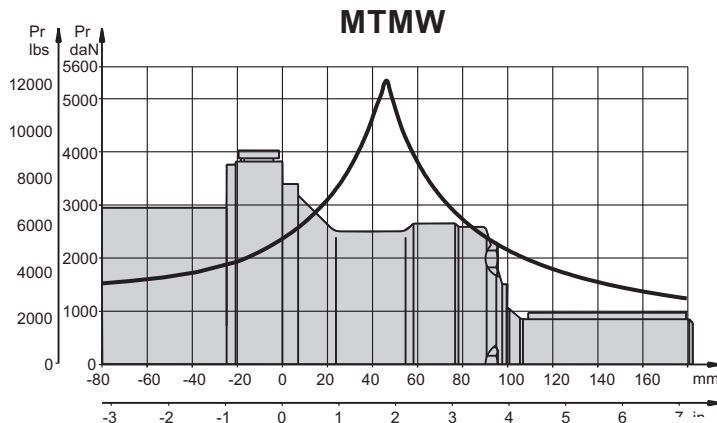
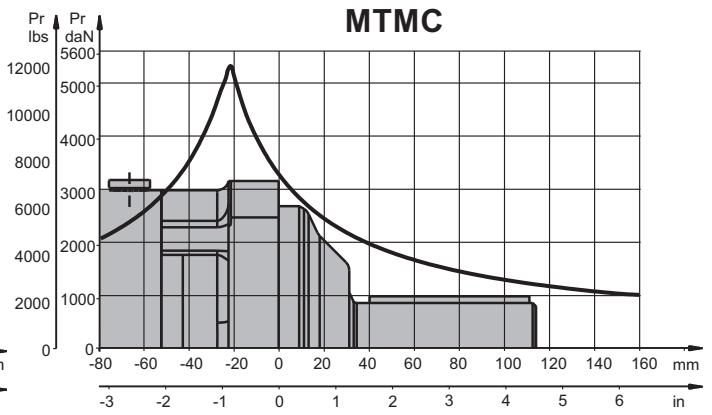
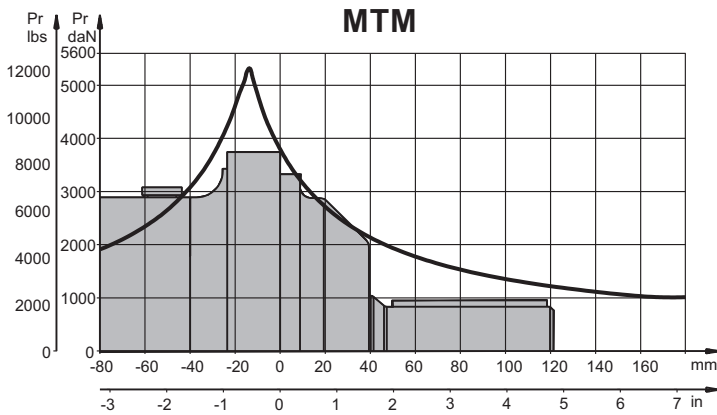

DIMENSIONS AND MOUNTING DATA - MTMV

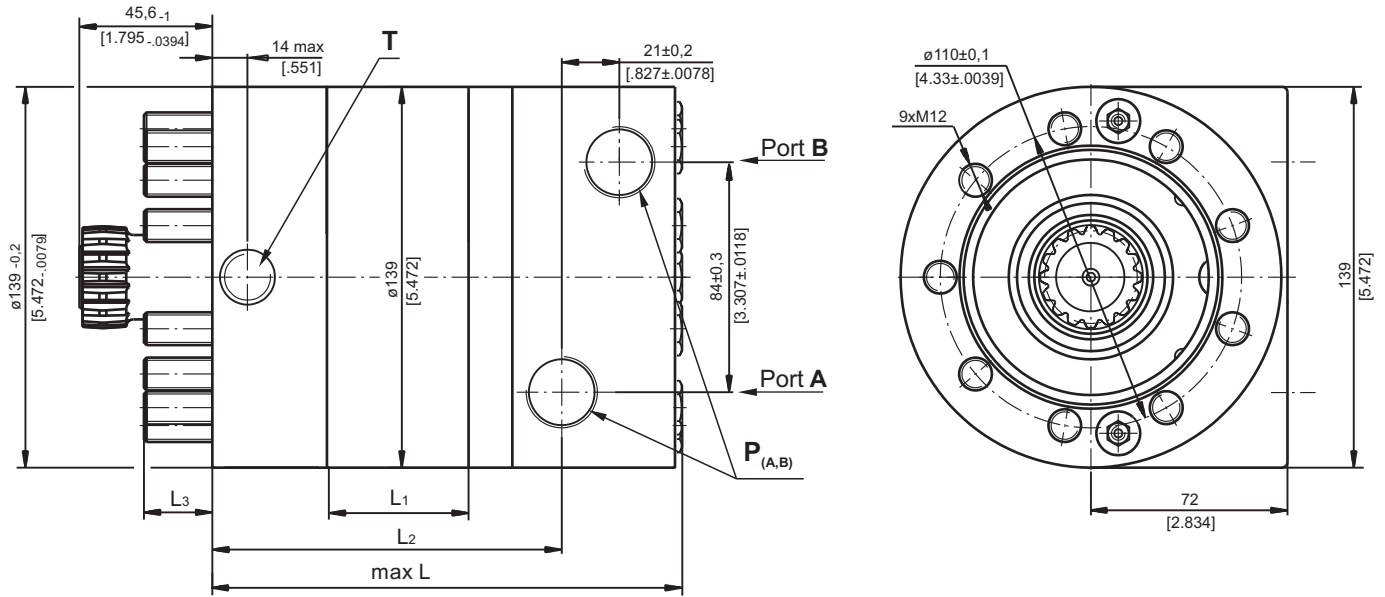

Warning: Drain line should always be used.

P_(A,B): 2xG3/4 - 17 mm [0.669 in] depth

T : G1/4 12 mm [0.472 in] depth (plugged)

Standard Rotation
Viewed from Shaft End
Port **A** Pressurized - **CW**
Port **B** Pressurized - **CCW**

Reverse Rotation
Viewed from Shaft End
Port **A** Pressurized - **CCW**
Port **B** Pressurized - **CW**

Type	L, mm [in]	L ₁ , mm [in]	L ₂ , mm [in]	L ₃ , mm [in]
MTMV 200	151 [5.945]	25 [0.98]	106,5 [4.193]	27,8 [1.094]
MTMV 250	157 [6.181]	31,3 [1.23]	112,8 [4.441]	26,5 [1.043]
MTMV 315	167 [6.575]	40,5 [1.59]	122,0 [4.803]	22,3 [0.878]
MTMV 400	177 [6.968]	51 [2.01]	132,5 [5.217]	21,8 [0.858]
MTMV 470	185 [7.283]	59 [2.32]	140,5 [5.531]	23,8 [0.937]
MTMV 500	191 [7.520]	65 [2.56]	146,5 [5.768]	27,8 [1.094]
MTMV 630	187 [7.362]	61 [2.40]	142,5 [5.610]	21,8 [0.858]
MTMV 725	196 [7.717]	70 [2.76]	151,5 [5.965]	22,8 [0.898]

DIMENSIONS OF THE ATTACHED COMPONENT

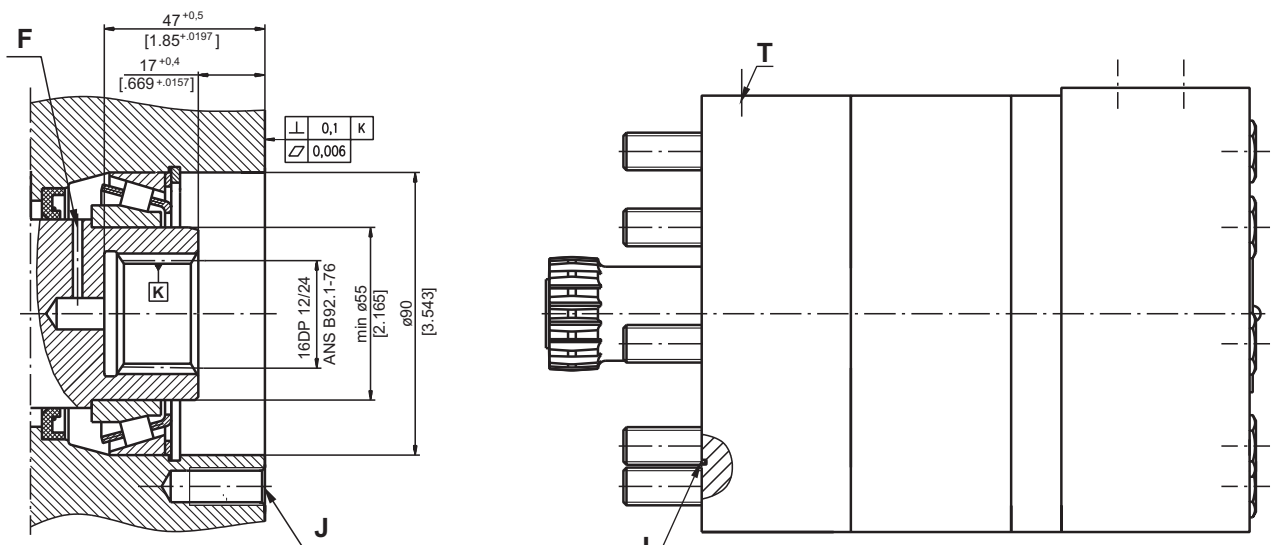

F: Oil circulation hole
J: 9xM12-30 mm [1.181 in] depth, 40°, ø110±0,1 [4.33±0.039]

I: O- Ring 93x1,5mm [3.661x.059 in]
T: Drain connection G1/4

DIMENSIONS AND MOUNTING DATA - MTM6V

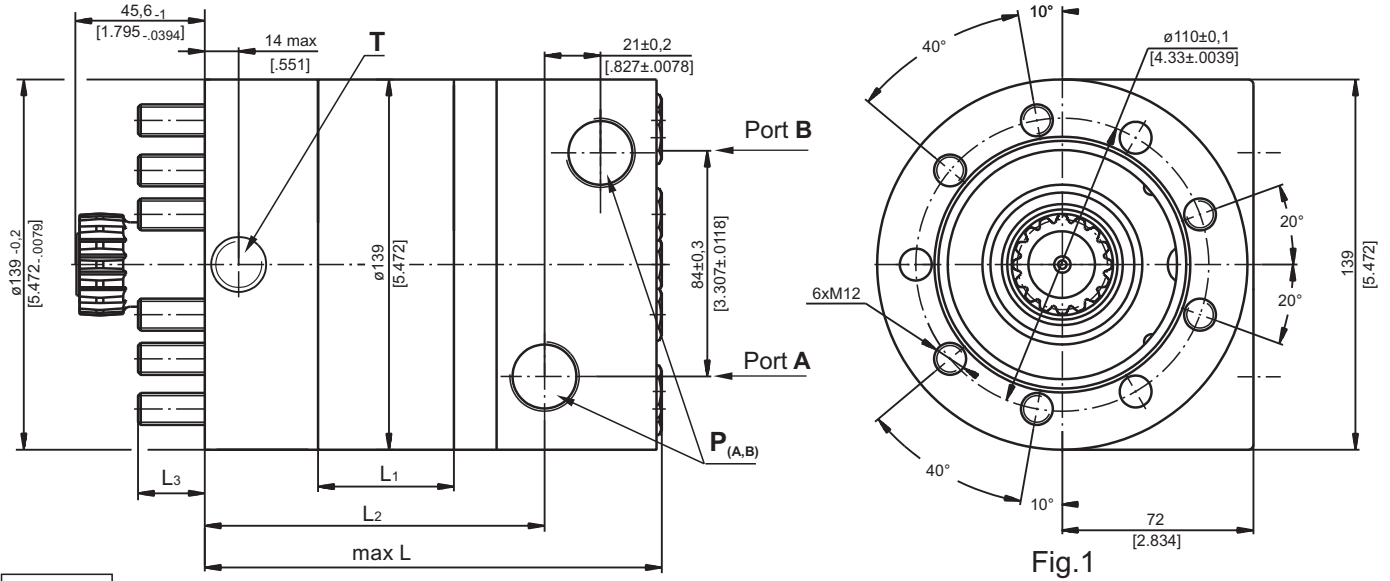

Warning: Drain line should always be used.

P_(A, B) : 2xG3/4 - 17 mm [.669 in] depth
T : G1/4 12 mm [.472 in] depth (plugged)

Standard Rotation
 Viewed from Shaft End
 Port A Pressurized - CW
 Port B Pressurized - CCW

Reverse Rotation
 Viewed from Shaft End
 Port A Pressurized - CCW
 Port B Pressurized - CW

Type	L, mm [in]	L ₁ , mm [in]	L ₂ , mm [in]	L ₃ , mm [in]
MTM6V 200	151 [5.945]	25 [.98]	106,5 [4.193]	27,8 [1.094]
MTM6V 250	157 [6.181]	31,3 [1.23]	112,8 [4.441]	26,5 [1.043]
MTM6V 315	167 [6.575]	40,5 [1.59]	122,0 [4.803]	22,3 [.878]
MTM6V 400	177 [6.968]	51 [2.01]	132,5 [5.217]	21,8 [.858]
MTM6V 470	185 [7.283]	59 [2.32]	140,5 [5.531]	23,8 [.937]
MTM6V 500	191 [7.520]	65 [2.56]	146,5 [5.768]	27,8 [1.094]
MTM6V 630	187 [7.362]	61 [2.40]	142,5 [5.610]	21,8 [.858]
MTM6V 725	196 [7.717]	70 [2.76]	151,5 [5.965]	22,8 [.898]

DIMENSIONS OF THE ATTACHED COMPONENT FOR MTM6V

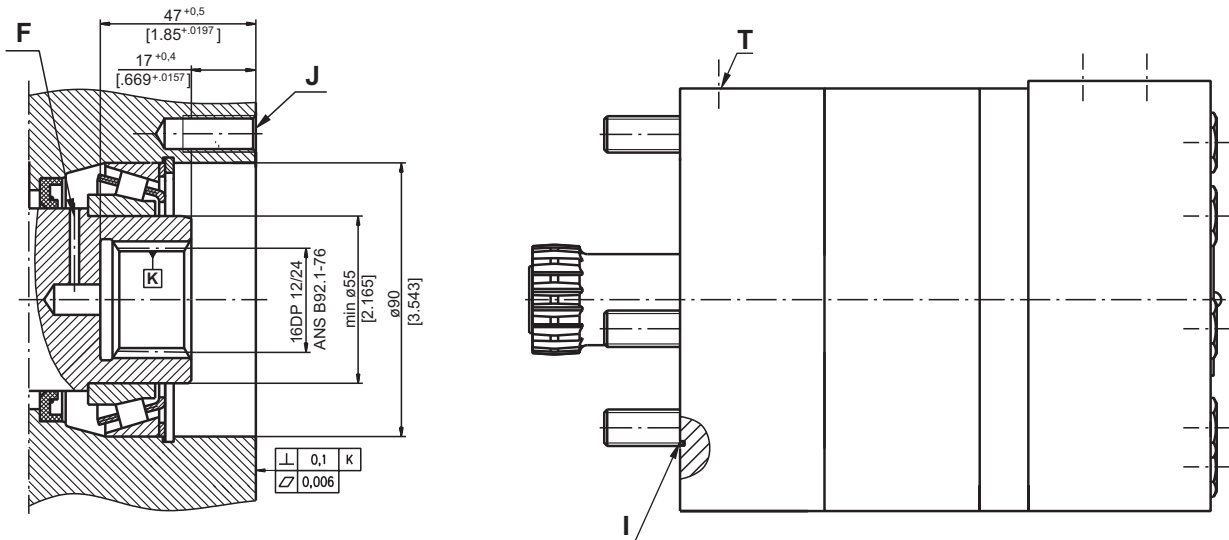

F: Oil circulation hole
J: 9xM12-30 mm [1.181 in] depth, 40°, $\phi 110 \pm 0,1$ [4.33±.0039]
 or 6xM12-30 mm [1.181 in] depth, situated in accordance with the bolts M12, shown on Fig.1, $\phi 110 \pm 0,1$ [4.33±.0039]
I: O- Ring 93x1,5mm [3.661x.059 in]
T: Drain connection G1/4

DRAIN CONNECTION

A drain line ought to be used when pressure in the return line can exceed the permissible pressure. It can be connected to the drain connection of the attached component. The maximum pressure in the drain line is limited by the attached component and its shaft seal.

The drain line must be possible for oil to flow freely between motor and attached component and must be led to the tank. The maximum pressure in the drain line is limited by the attached component and its seal.

INTERNAL SPLINE DATA FOR THE ATTACHED COMPONENT

Standard ANS B92.1-1976, class 5
 [m=2.1166; corrected x.m=+1,0]

Fillet Root Side Fit		inch	mm
Number of Teeth	z	16	16
Diametral Pitch	DP	12/24	12/24
Pressure Angle		30 ⁰	30 ⁰
Pitch Dia.	D	1.3333	33,8656
Major Dia.	D _{ri}	1.5118÷1.5275	38,4 ^{+0,4}
Minor Dia.	D _i	1.2657÷1.2673	32,15 ^{+0,04}
Circular Space Width	Lo	.1763÷.1791	4,516±0,037
Fillet Radius	R	.02	0,5
Dimension Between Two Pins	L	1.063÷1.059	26,9 ^{+0,10}
Pin Dia.	d	.19026÷.19034	4,835±0,001

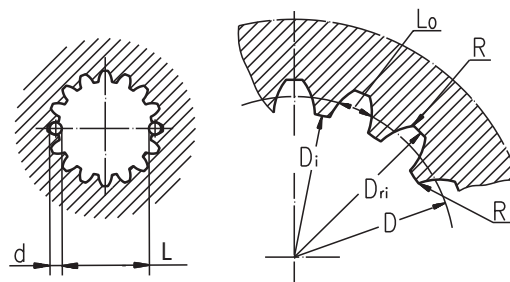

Hardening Specification:
 HV=750±50 on the surface.
 HV=560 at 0,7±0,2 [.035±.019] case depth
 Material: 20 MoCr4 EN 10084 or SAE8620.

ORDER CODE

	1	2	3	4	5	6	7
MTM						HD	

Pos.1 - Mounting Flange

omit - 4-Bolt flange, spigot dia. ø160, BC ø200

C - 4-Bolt flange, spigot dia. ø125, BC ø160

W - Wheel motor

V - Veryshort mount, 9xM12 mounting bolts

6V - Veryshort mount, 6xM12 mounting bolts

Pos.2 - Displacement code

200 - 201,4 cm³/rev [12.29 in³/rev]

250 - 251,8 cm³/rev [15.36 in³/rev]

315 - 326,3 cm³/rev [19.90 in³/rev]

400 - 410,9 cm³/rev [25.06 in³/rev]

470 - 475,0 cm³/rev [28.97 in³/rev]

500 - 523,6 cm³/rev [31.95 in³/rev]

630 - 631,2 cm³/rev [38.52 in³/rev]

725 - 724,3 cm³/rev [44.20 in³/rev]

Pos.3 - Shaft Extensions*

C - ø40 straight, Parallel key A12x8x70 DIN6885

CO - ø1½" straight, Parallel key 3/8"x3/8"x2¼" BS46

K - ø45 tapered 1:10, Parallel key B12x8x28 DIN6885

SH - ø1½" splined 17T ANSI B92.1-1976

Pos.4 - Check Valves

omit - without check valves

1 - with check valves

Pos.5 - Ports

omit - BSPP (ISO 228)

Pos.6 - Special Features

HD - Reinforced motor **HD****

For Other **Special Features** see page 48

Pos.7 - Design Series

omit - Factory specified

NOTES:

* The permissible output torque for shafts must not be exceeded!

** Drain line should always be used.

The hydraulic motors are manganophosphatized as standard.